



DIGITAL INDICATOR - TOTALIZER TRANSMITTER

MODEL TR28-2

OPERATION AND MAINTENANCE MANUAL PARTS LIST

FEATURING:

- *MODEL CN08-2 DIGITAL INDICATOR-TOTALIZER
- *ENCAPSULATED ELECTRONICS
- *SOLID STATE CONSTRUCTION
- *CURRENT OUTPUT SIGNAL
- *PULSE OUTPUT SIGNAL
- *SEALED HOUSING



**3255 WEST STETSON AVENUE
HEMET, CALIFORNIA 92545 U.S.A.**

**PHONE: 951-652-6811
FAX: 951-652-3078
VISIT OUR WEBSITE: www.mccrometer.com**

WARRANTY

This Warranty shall apply to and be limited to the original purchaser consumer of any McCrometer product. Meters or instruments defective because of faulty material or workmanship will be repaired or replaced, at the option of McCrometer, free of charge, FOB the factory in Hemet, California, within a period of one (1) year from the date of delivery.

Repairs or modifications by others than McCrometer or their authorized representatives shall render this Warranty null and void in the event that factory examination reveals that such repair or modification was detrimental to the meter or instrument. Any deviations from the factory calibration require notification in writing to McCrometer of such recalibrations or this Warranty shall be voided.

In case of a claim under this Warranty, the claimant is instructed to contact McCrometer, 3255 W. Stetson Ave., Hemet, California 92545, and to provide an identification or description of the meter or instrument, the date of delivery, and the nature of the problem.

The Warranty provided above is the only Warranty made by McCrometer with respect to its products or any parts thereof and is made expressly in lieu of any other warranties, by course of dealing, usages of trade or otherwise, expressed or implied, including but not limited to any implied warranties of fitness for any particular purpose or of merchantability under the uniform commercial code. It is agreed this Warranty is in lieu of and buyer hereby waives all other warranties, guarantees or liabilities arising by law or otherwise. Seller shall not incur any other obligations or liabilities or be liable to buyer, or any customer of buyer for any anticipated or lost profits, incidental or consequential damages, or any other losses or expenses incurred by reason of the purchase, installation, repair, use or misuse by buyer or third parties of its products (including any parts repaired or replaced); and seller does not authorize any person to assume for seller any other liability in connection with the products or parts thereof. This Warranty cannot be extended, altered or varied except by a written instrument signed by seller and buyer.

This Warranty gives you specific legal rights, and you may also have other rights which vary from state to state.

McCrometer reserves the right to make improvements and repairs on product components which are beyond the Warranty period at the manufacturer's option and expense, without obligation to renew the expired Warranty on the components or on the entire unit. Due to the rapid advancement of meter design technology, McCrometer reserves the right to make improvements in design and material without prior notice to the trade.

All sales and all agreements in relation to sales shall be deemed made at the manufacturer's place of business in Hemet, California and any dispute arising from any sale or agreement shall be interpreted under the laws of the State of California.

**MODEL TR28-2
DIGITAL INDICATOR-TOTALIZER-TRANSMITTER
INDEX**

- I. DESCRIPTION**
- II. SPECIFICATIONS**
- III. UNPACKING**
- IV. INSTALLATION**
- V. METERS**
1. Remove
 2. Clean Meter Head
 3. Transmitter Mounting Base
 4. Position of Indicator-Totalizer-Transmitter
 5. Transmitter Wiring
- VI. OPERATION AND MAINTENANCE MANUAL**
- VII. PRINCIPALS OF OPERATION**
1. TR28-2 Functions
 2. Battery
 3. Power to TR28-2
- VIII. SENSOR and TR28-2 DIGITAL INDICATOR-TOTALIZER-TRANSMITTER**
1. TR28-2 Digital Transmitter
 2. TR28-2
 3. Sensor Assembly
 4. Battery Replacement
- IX. TROUBLESHOOTING**
1. Troubleshooting Guide
 2. Working Area
 3. TR28-2 Digital Transmitter
 4. Moisture
 5. Transmitter Communication Lines
 6. TR28-2 Circuit
- X. INSPECTION**
- XI. REASSEMBLY**
- XII. INOPERATIVE INSTRUMENT EVALUATION**
1. Check All Instruments and Transmitters
 2. Check Your Instrument
 3. Transmitter or Communication Line
 4. Full Scale Output
 5. Transmitter Communication Lines
 6. Communications Problems
 7. Separation of Signal and Power

- I. DESCRIPTION:**
The Model TR28-2 Digital Indicator Totalizer Transmitter provides flow rate indication, totalization of flow volume and a current output signal proportional to the rate of flow when mounted on our meters. The TR28-2 is for installation on propeller meters.
- II. SPECIFICATIONS:**
- | | | |
|---------------------------|--|--|
| ACCURACY | Rate | ±0.25% of reading. |
| TEMPERATURE | Operation: | 32° to 160° F. |
| | RANGE | Storage: -40° to 160° F. |
| | | Consult factory for special construction for other temperatures. |
| INPUT SIGNAL | Type: | Voltage pulse. |
| | Voltage Range: | 1 to 10V. |
| | Minimum Frequency: | 0.125Hz. |
| | Maximum Frequency: | 3KHz. |
| | Minimum Pulse Width: | 2μs. |
| OUTPUT SIGNALS | <u>Combination 4-20mA Output and Isolated Scaled Pulse Output:</u> | |
| | Standard 2 wire loop powered. | |
| | 16 bits resolution. | |
| | Operating voltage: | 12 to 32 VDC. |
| | Power Switch: | Auto battery override. |
| | <u>Scaled Pulse Output:</u> | |
| | Open collector MOS transistor. | |
| | Pulse width: | 32 milliseconds. |
| | Maximum Rating: | 1 to 32 V. |
| EMI/EMC | Electrostatic Discharge: | 8KV |
| | | (IEC 1000-4-2 Level 3). |
| | Electrical Fast Transient: | 1KV |
| | | (IEC 1000-4-4 Level 3). |
| | RF Susceptibility: | 150 KHz to 230 MHz @ 10V |
| | | (IEC 1000-4-4 Level 3). |
| POWER SUPPLY | 24 VDC (as supplied by our power supply Model IN36-1, available separately) wired in series. | |
| | The Indicator-totalizer-transmitter is primarily loop powered, but becomes self-powered via a lithium battery in the event of a power loss. | |
| | Battery Type - 3 VDC Lithium, Replaceable | |
| | Operating Life - 2 years (when used with the display timeout into sleep mode feature). | |
| | Low Battery Indication - 6 months before expiration. | |
| OPTIONAL EQUIPMENT | Mounting brackets, with up to 100 feet of cable for remote installation. | |
| SHIPPING WEIGHT | 4 pounds. | |
| ORDERING INFO | Must be specified by the customer and includes serial number of meter on which unit is to be mounted, maximum scale range required for 4-20 output, indicator scale and units, totalizer dial units. Consult factory for special applications. | |

III. UNPACKING. When unpacking the transmitter, any damage due to rough or improper handling should be reported to the transportation firm and McCrometer. If for any reason it is determined that the unit or parts of the unit should be returned to the factory, please contact McCrometer for clearance prior to shipment. Each unit must be properly packaged to prevent any further damage. The factory assumes no responsibility for equipment damaged in return shipment due to improper packaging. Proper paperwork must be enclosed with any returned material.

The shipping carton contains the following items:

Model TR28-2	1
Mounting Base O-ring	1
Mounting Base (w/hardware)	1
Operation and Maintenance Manual	1

IV. INSTALLATION of transmitters is normally done at the factory when the meter is assembled, but may be made in the field. Depending upon what situation exists, various steps for installation apply and the procedures are outlined below.

V. METERS with mechanical drive totalizers or indicator-totalizers require a conversion kit. This kit consists of all necessary parts to convert a mechanical drive meter into an electronic meter. Follow the instructions included with the conversion kit for your meter. Once conversion is complete, follow the procedures outlined below for installation of Model TR28-2 on an electronic meter.

1. **REMOVE** the existing digital indicator by removing the four mounting screws. Lift the unit slightly, turn it over, and disconnect the two lead sensor from the bottom of the indicator.

2. **CLEAN METER HEAD** of all dirt, glue, gaskets and, other foreign material.

3. **TRANSMITTER MOUNTING BASE (#10)** and O-ring (#12) must be installed on the meter head. Position the mounting base (#10) so the watertight connector (#14) and transmitter output cable (#13) are on right side of meter when looking upstream. Apply a small amount of silicone grease to the O-ring (#12). Secure base to meter with four mounting screws (#11). Connect the sensor wires from the meter to the bottom of the TR28-2. Be sure terminals are secure. The sensor wires should pass through the hole in the base cup (#8). (See wiring diagrams on page 10 or 11.)

4. **POSITION OF INDICATOR-TOTALIZER TRANSMITTER** on top of the mounting base can be made in one of four directions for the easiest possible reading. Normally the units are attached so that they can be read when looking upstream. Prior to mounting the transmitter on the mounting base, the wiring connections must be made to the transmitter. Connect the wire from the transmitter output cable (#13) to the mA output terminal on the bottom of the unit. The output is polarized. Be sure terminal is secure. **DO NOT TOUCH ANY OF THE OTHER TERMINALS ON THE BOTTOM OF THE TRANSMITTER.** Apply a small amount of silicone grease to the base cup O-ring (#2) and secure transmitter bonnet with four mounting screws (#3).

5. **TRANSMITTER WIRING** can be accomplished by following the wiring diagram on page 8, 10 or 11.

TRANSMITTER OPERATION AND MAINTENANCE MANUAL

VI. MCCROMETER products have been carefully designed to be as maintenance-free as possible. Periodic preventive maintenance, however, is highly recommended and should be practiced according to schedule to ensure continuous accuracy and trouble-free performance of your meter. The maintenance and inspection procedure can also be used as a guide to locating a problem in the transmitter that may be the cause of abnormal operation.

NOTE: METER DISPLAY WILL SHUT OFF AFTER A FEW MINUTES WITH THE LID OPEN. TO READ METER, CLOSE LID AND OPEN IT AGAIN.

VII. PRINCIPALS OF OPERATION

1. The Model TR28-2 has four separate functions:

1. A 4-20 mA output signal operated through the 24 VDC loop power from the instrument.
2. Digital display rate of flow going through the meter.
3. Digital display of total flow that has gone through the meter from when first installed.
4. Scaled Pulse output of one pulse per totalizer count.

2. A battery is built into the Model TR28-2 as a backup for the rate and totalizer only in case of a power failure. It should be understood how this backup battery operates when the 24 VDC loop power is off:

1. The 4-20 mA signal stops.
2. The digital rate and totalizer display stays on until it goes into programmed sleep mode. (See Programming Guide, Literature #30110-17.)
3. Because the unit has a built in EEPROM memory, the totalizer will still be storing totalizer information even though it is not displayed.

3. When the power comes back on, the Model TR28-2 will:

1. Send a 4-20 mA signal to the instrument when flow starts.
2. It will display flow rate on the Model TR28-2 when lid is opened.
3. It has been storing all quantity going through the meter and will display totalizer by opening lid.

VIII. SENSOR AND TR28-2 DIGITAL INDICATOR-TOTALIZER-TRANSMITTER

1. **TR28-2 DIGITAL TRANSMITTER (#4)** should not be removed from the meter unless battery or sensor replacement is required or if the unit is to be reprogrammed. If the unit must be removed, proceed as follows:

2. **TR28-2 (#4)** can be removed from the transmitter mounting base (#10) by removing the four bonnet mounting screws (#3).

REPROGRAMMING: The bonnet can be lifted enough to slide the base cup and digital transmitter out of the bonnet, allowing access to the programming buttons. (See Programming Guide, Literature #30110-17.)

3. **SENSOR ASSEMBLY** in the meter can be replaced by following the meter instruction manual.

4. **BATTERY REPLACEMENT (#6):** The 3 Volt Lithium Battery is used as a backup to the 24 VDC loop power. In the event of a power loss, the battery will continue to operate the rate and total functions of the TR28-2. The "low battery" indication will appear approximately 6 months prior to expiration.

A. The bonnet (#1) can be lifted enough to access the terminals connected to sensor input and transmitter pulse/mA output.

B. Carefully disconnect the wires from the transmitter. The unit can then be turned over and the battery can be accessed through the opening in the bottom of the base cup. Be sure to install the new battery with the positive (+) and negative (-) terminals positioned properly.

C. Reconnect the wires to the transmitter. (See page 9.)

D. Reinsert the TR28-2 (#4) into the bonnet assembly (#1) with the **top of dial aligned with the hinge side of the bonnet.**

E. Install the bonnet O-ring (#2) into bonnet with a coating of silicone grease.

NOTE: Batteries should be disposed of in an environmentally sound manner.

IX. **TROUBLESHOOTING** the transmitter is necessary if it is apparent that the instrument being controlled by the transmitter is not receiving a proper signal from the transmitter, and/or the totalizer or indicator-totalizer is not functioning. Before beginning, it is important to be sure that the problem is with the transmitter.

The following checks should be made:

- 1) Check to be sure that water is flowing through the meter at flows above the minimum flow rate for the given size meter.
- 2) Check the instrument to be sure it has the required power being supplied to it.
- 3) Check the junction box to be sure the communication lines from the transmitter to the instrument are making good contact and that the transmitter is wired properly to the instrument. (See wiring diagrams on page 8, 10 or 11.)

1. **THE TROUBLESHOOTING GUIDE** is provided to help isolate any problem that may occur with the transmitter. Follow the instructions and test procedures listed for each problem.

NOTE: The meter assembly should be inspected thoroughly to be sure it is operating properly and is not the cause of the problem. (Refer to your meter service manual for instruction on inspection of the meter.)

A. If the meter indicator-totalizer **does** work, but the remote instrument **does not** operate (not receiving proper signal), and if the 24 VDC loop power to the Model TR28-2 is now on, then use troubleshooting procedures 2, 3, 5, 6, X, XI and XII.

B. If the meter indicator-totalizer and remote instrument **do not** operate, check the TR28-2 by opening and closing the lid twice. If no response, then follow all procedures.

2. **WORKING AREA** chosen for testing and inspection of the internal components should be clean to reduce the chance of dust or dirt particles being introduced into the transmitter mechanism.

3. **TR28-2 DIGITAL TRANSMITTER** must be removed from the mounting base (#10) to gain access to the transmitter terminals and to check connections. Remove the unit from the mounting base following instructions in section VIII. Check the connection from the sensor in the meter to the terminals in the bottom of the TR28-2. Check the connection from the pulse and mA terminals on the TR28-2 to the instrument. Make sure the connection is clean and tight, and that the terminal is secure.

4. **MOISTURE** should not be apparent within the transmitter bonnet (#1). All O-rings should be inspected for breaks or presence of foreign materials that allow leakage to occur. Check to be sure water is not coming up through the meter head. If water is coming up through the meter head then the meter should be checked. (See meter service manual.)

5. **TRANSMITTER COMMUNICATION LINES (#13)** should be checked to determine the current level flowing in the loop. The method of measurement is to insert a multimeter into the 4-20 mA loop by disconnecting one of the mA signal wires, clipping one side of multimeter to disconnected wire and connecting other end of multi-meter to the lug or post from which the wire was removed.

A. If **no water is flowing** through the meter, the current level should be 4.0 mA. The purpose of the 4.0 mA at no flow is to ensure that the loop is complete. If there is 4.0 mA in the loop when no water is flowing, then the loop is intact.

B. If **water is flowing** through the meter, the current level should be between 4 and 20 mA, depending on flow.

6. **TR28-2 CIRCUIT** should be checked to be sure it is functioning properly. The circuit may be checked as follows:

A. If the current level in the loop is 0.0 mA, check the voltage between the mA terminals at the transmitter. It should be at the maximum power supply level (± 1.0 VDC).

If there is no voltage present, then check the loop voltage at its source. If there is voltage at the voltage source, then there is an opening in the loop.

If there is no voltage at the power supply, disconnect loop and check supply by itself. If the voltage level is still 0 VDC or very low (< 10 VDC), replace power supply.

B. If the level of current is greater than 20 mA, there are two possibilities. The TR28-2 may be starting to fail, but unless there has been some major damage done to the unit (physical impact or voltage levels above

50 VDC applied), it should not exceed 21.00 mA.

High loop current can also be caused by a short in the transmitter hookup cable. A zero Ohm short will cause power supply fuse to blow. However, it is possible to have a shunt of about 0.5W to 10W connecting transmitter lines, which will cause excessive loop current with transmitter in system (from 70.0 - 350 mA or more), but when TR28-2 is tested separately it works fine. These shorts are difficult to find. They can be caused by incorrect wiring installation or damage to wiring. Damage can be caused by physical contact (back hoe, etc.) or from environmental effects (water in the raceways).

C. If transmitter output remains at 4.0 mA even when the meter and sensor are operating properly, the TR28-2 must be replaced.

If the loop current is within a satisfactory range, 3.90 mA to 21.00 mA, and varies with a varying flow rate, but is not showing desired values, the unit can be programmed with different totalizer, rate scale, zero mA value, and full scale mA value. (See Programming Guide, Literature #30110-17.)

X. INSPECTION and field testing has been accomplished at this point. Should any of the parts, upon inspection, appear to be damaged, they must be replaced to ensure proper operation and prevent further damage.

XI. REASSEMBLY is necessary at this point. Before reassembling, make certain that the unit is cleaned of any dust or dirt. Costs for replacement parts not covered by warranty are available by contacting the factory.

BEFORE RETURNING TRANSMITTER TO FACTORY, please notify McCrometer. Each unit must be properly packaged to prevent damage to the product during shipment. Should any of the unit's parts, upon inspection, appear to be damaged, they must be replaced to ensure proper operation and prevent further damage. Costs for replacement parts not covered by warranty are available from current parts and price list. Should the unit require further inspection, it must be reassembled and returned to the factory.

XII. PROCEDURES FOR CHECKING OUT INOPERATIVE INSTRUMENT SYSTEMS:

Each instrument is factory-tested with the transmitter that will be operating it. When an instrument doesn't operate and is connected to its proper transmitter, certain procedures need to be followed to determine where and what the problem is. Most troubleshooting procedures are part of each instrument and transmitter service manual, but these suggestions may help.

1. CHECK ALL INSTRUMENTS AND TRANSMITTERS for obvious visual damage. Make certain any necessary grounding has been made.

2. CHECK YOUR INSTRUMENT to be sure it is operating properly by following the instrument service manual. Check to be sure your instrument is operating correctly when a simulated signal is put into it.

WARNING: Circuit to transmitter must be disconnected when most testing equipment is used for checking your instrument. If instrument checks out, proceed with checking transmitter and communication lines.

3. WHEN THE TRANSMISSION OR COMMUNICATION LINE is suspected of being the reason the system is not functioning, it is usually easier to check the transmitter first to be sure it is giving proper output. There are some easy troubleshooting techniques for checking mA output. First, you must know what mA signal is expected from the transmitter.

A. Model TR28-2 current transmitter has an output of 4 to 20 mA at maximum scale of the instrument it operates.

B. The original purchaser of the equipment should have invoices or other paperwork to confirm what the 4 to 20 scale is. If not, contact the factory with the meter serial number and the factory will provide the full scale information.

C. Let us assume you found the meter was a 12" meter and the full scale of the instrument is 3,000 GPM.

4. FULL SCALE OUTPUT. Once the output at full scale has been determined, we need find out what the unit is measuring at.

A. Time the transmitter totalizer with a stopwatch for 3 to 5 minutes, to give the best resolution or closest accuracy.

B. The example meter has a 1,000 gallon totalizer and, if you time the totalizer for three counts in 150 seconds, proceed as follows:

$$150 \text{ sec} \div 3 = 50 \text{ sec for 1,000 gallons (1 count)}$$

C. To find the true flow rate:
 $60 \text{ sec} \div \text{number of sec per count} \times \text{totalizer dial}$
 (or as shown below)

$$60 \div 50 \times 1,000 = 1,200 \text{ GPM true flow rate}$$

Now verify the indicator is accurate.

D. To determine what output the transmitter should be sending, we must now find what percent 1,200 GPM is of the 3,000 GPM scale stated earlier.
 $1,200 \text{ GPM} \div 3,000 \text{ GPM} = 40\%$
 Because 4 mA equals ZERO it must be subtracted from 20 mA.

Therefore, $20 - 4 = 16 \text{ mA usable output (SPAN)}$
 $40\% \times 16 \text{ mA} = 6.4 \text{ mA}$ then add 4 mA back to give 10.4 mA @ 1,200 GPM.

E. The 4-20 mA current signal can be checked by using a digital multimeter. Have the multimeter set to measure milliamps. With no water flowing through the meter, the ammeter should measure 4.0 mA. If water is flowing through the meter, the current level should be between 4 to 20 mA.

NOTE: A.C. power should be removed from circuit before inserting the multimeter. The multimeter must be connected in series with circuit being tested.

5. TRANSMITTER COMMUNICATION LINES (#13) should be checked to determine if the pulse output is present.

WARNING: A.C. power should be disconnected to the instrument prior to any work taking place on the wiring.

A. The preferred method of checking the pulse output is to use a McCrometer Model IN16 attached to the pulse output of the TR28-2. The McCrometer IN16 will count each time the transmitter sends a pulse.

B. A voltmeter can also be used to check the pulse output. Using a voltmeter, on 0 to 5 VDC scale, measure voltage between the two pulse output wires when the totalizer count changes. It will display a pulse voltage every time the totalizer counts. (The voltage displayed will depend on how quickly your meter responds.)

If the pulse is present at the instrument, then the problem is with the instrument. If the pulse is not present, perform the same tests at the junction box and at the transmitter itself. If the pulse is present at the junction box, then the problem is with the communication lines from the junction box to the instrument. If the pulse is present at the transmitter, there is something wrong in the communication lines between the transmitter and the instrument. If no pulse can be measured, the unit must be returned to the factory. (See section XI, 1.)

6. COMMUNICATION PROBLEMS can be so complex it is usually recommended the instrument contractor or electrical contractor be informed that our transmitters and indicators prove to be good units and the trouble could be elsewhere. Sometimes it is necessary to lay another line from the transmitter to instrument above ground to help prove the lines are at fault prior to pulling and replacing existing line. Communications lines should be kept from tangling up in high voltage lines inside the panel or wiring cabinet. Communication lines should be shielded cable and not run in same conduit as power lines. Sometimes the 115 V A.C. line used for the instrument can be causing the trouble. It is suggested the plug from the instrument be temporarily transferred to another A.C. outlet which is on another circuit. It has been found a fluorescent light circuit tied in with the instrument power source, or faulty parking lot vapor lights can affect the instruments if A.C. wiring is done incorrectly, giving a noisy A.C. circuit. Make certain the ground is connected to earth ground.

7. SEPARATION OF SIGNAL AND POWER wiring in separate conduits is the traditional precaution; however, other measures must be taken to minimize the effects of electromagnetic interference (EMI) and radio frequency interference (RFI) on the operation of the instrument. Otherwise, if high level, short duration noise spikes are permitted to enter the digital equipment, the noise can be transferred into the systems logic networks and can be misinterpreted as signal data, resulting in erroneous system operation and other unpredictable responses. Potential noise sources:

- Relay coils
- Solenoids
- AC power wires
- Current carrying cables
- Radio frequency transmissions

PULSE OUTPUT WIRING WHEN USED WITH MODEL IN16

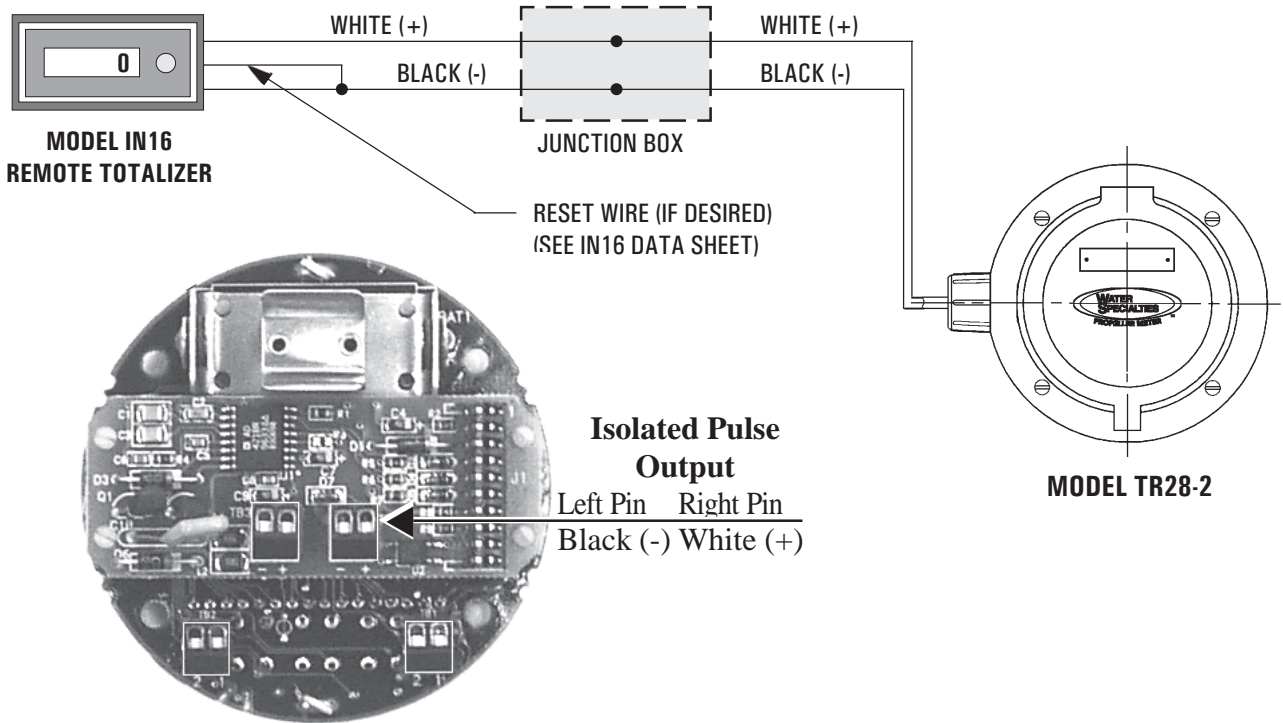

PULSE OUTPUT WIRING WHEN USED WITH AUXILIARY EQUIPMENT

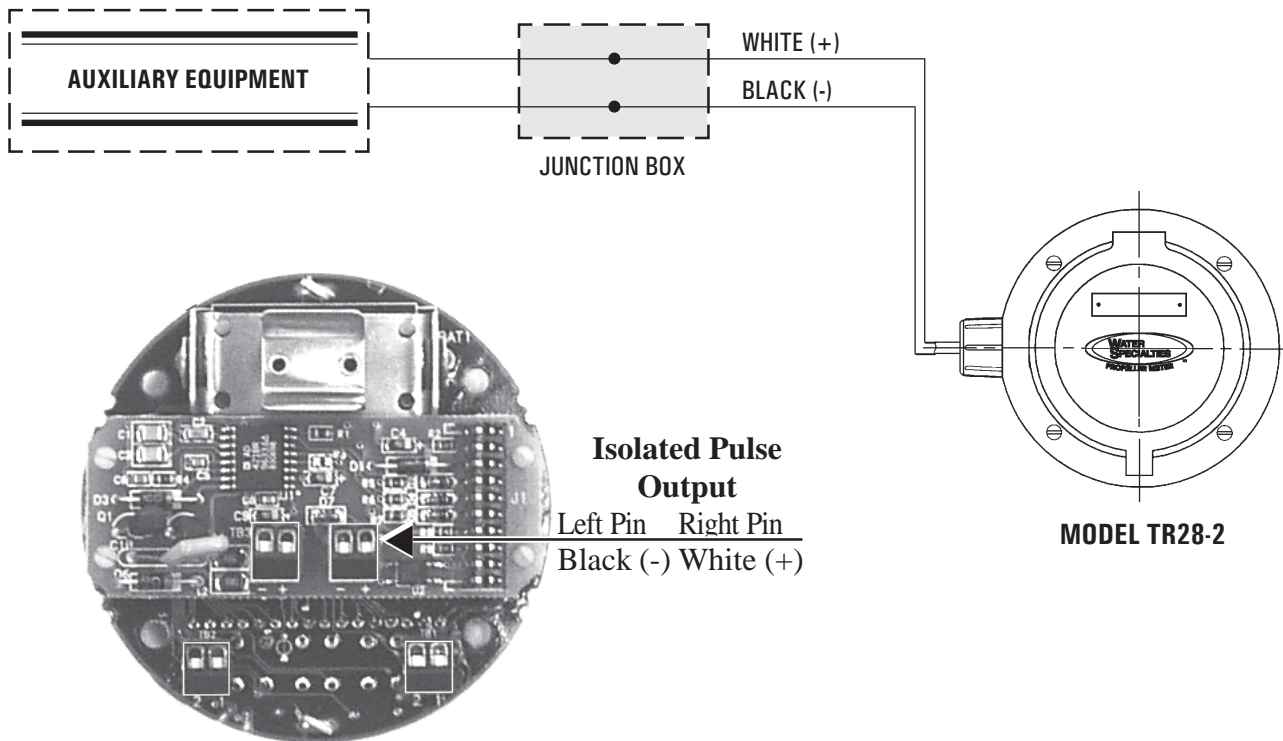

MODEL TR28-2

INDICATOR - TOTALIZER - TRANSMITTER

- SOLID STATE CONSTRUCTION ● CURRENT OUTPUT ● PULSE OUTPUT SIGNAL
- ONE PULSE PER TOTALIZER COUNT ● DIGITAL DISPLAYS

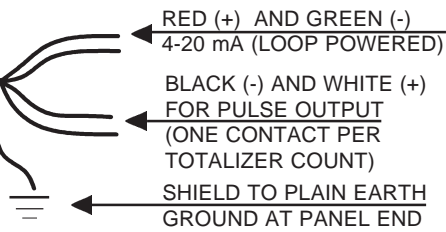
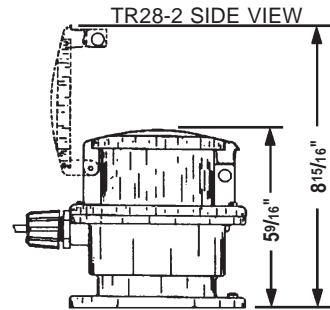
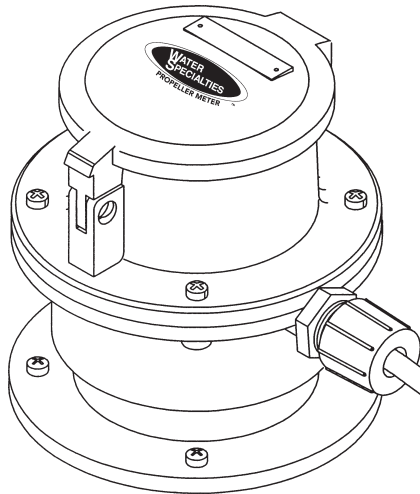

Power Supply	Power Supply Voltage for Loop	Maximum Resistance of Instruments in Loop
Variable	15.0VDC	150Ω
Variable	18.0VDC	300Ω
Variable	21.0VDC	450Ω
IN36-1(24V)	24.0VDC	600Ω
Variable	27.0VDC	750Ω
Variable	30.0VDC	900Ω

NOTES:

The transmitter will drive up to a maximum of 600 ohms loop resistance.

Wire Size Information:

The distance of the communication line from transmitter to the device the 4-20mA will operate depends on the loop resistance, the wire size, and the power supply. Based on a 24V DC power supply and 22 gauge wire, we recommend a maximum loop of 3,500 feet.

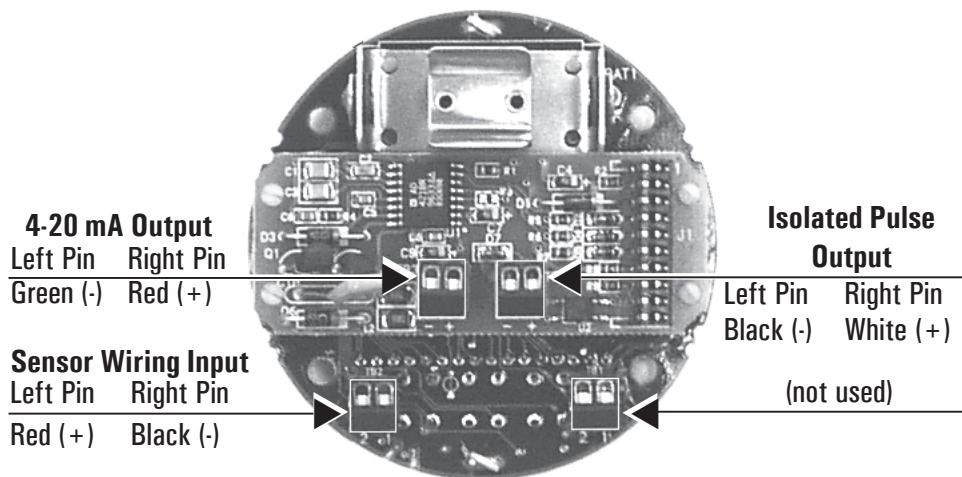

TESTING TRANSMITTER OUTPUT AND POWER SUPPLY VOLTAGE

TR28-2 TRANSMITTER (4-20 mA OUTPUT)
WIRED TO A MODEL IN60

NOTE: Connections for measuring the amount of current flowing in the 4-20 mA loop. There should be 4.0 mA with no water flowing through meter and 20.0 mA at full scale. Connect ammeter in series with circuit.

4-20 mA Output
Left Pin Right Pin
Green (-) Red (+)

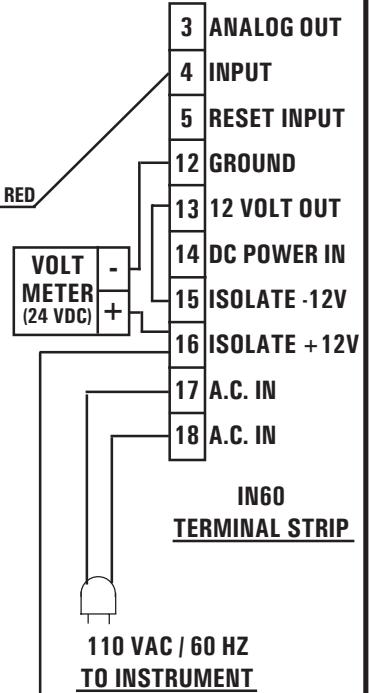
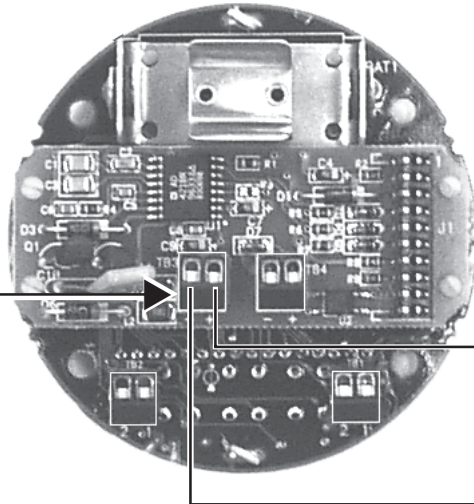

NOTE: TRANSMITTER CABLE SHIELD TO GROUND.

NOTE: Connections for checking power supply voltage for the transmitter. (24 VDC) connect voltmeter in parallel with circuit.

TESTING TRANSMITTER OUTPUT AND POWER SUPPLY VOLTAGE

TR28-2 TRANSMITTER (4-20 mA OUTPUT)
WIRED TO A MODEL IN48 12" CHART RECORDER *SOLD BEFORE 05/93*

NOTE: Connections for checking transmitter power supply voltage (24 VDC). Connect voltmeter in parallel with circuit.

TRANSMITTER POWER
(24 VDC)

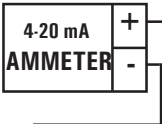
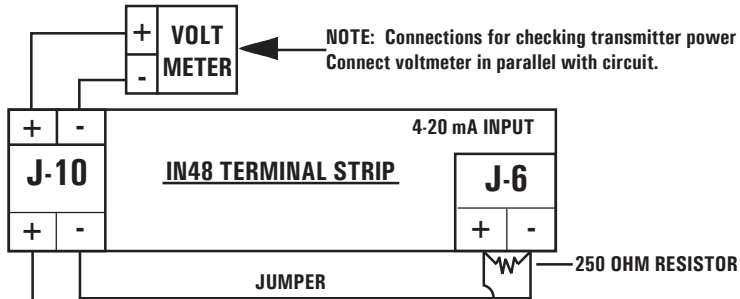

4-20 mA Output
Left Pin Right Pin
Green (-) Red (+)

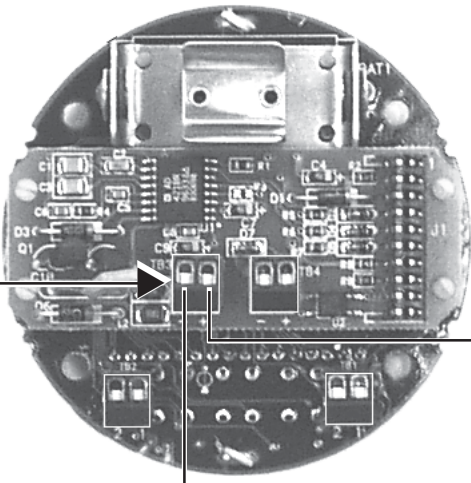

NOTE: Connections for measuring the amount of current flowing in the 4-20 mA loop. There should be 4.0 mA with no water flowing through meter and 20.0 mA at full scale. Connect ammeter in series with circuit. If there is no current in the loop and the power supply voltage is there, then the problem is possibly in the communication lines or the transmitter circuit board.

NOTE: TRANSMITTER CABLE SHIELD TO GROUND.

WIRING DIAGRAM FOR TR28-2 TO IN41
TR28-2 TRANSMITTER (4-20 mA OUTPUT)
WIRED TO A MODEL IN41 10" CHART RECORDER

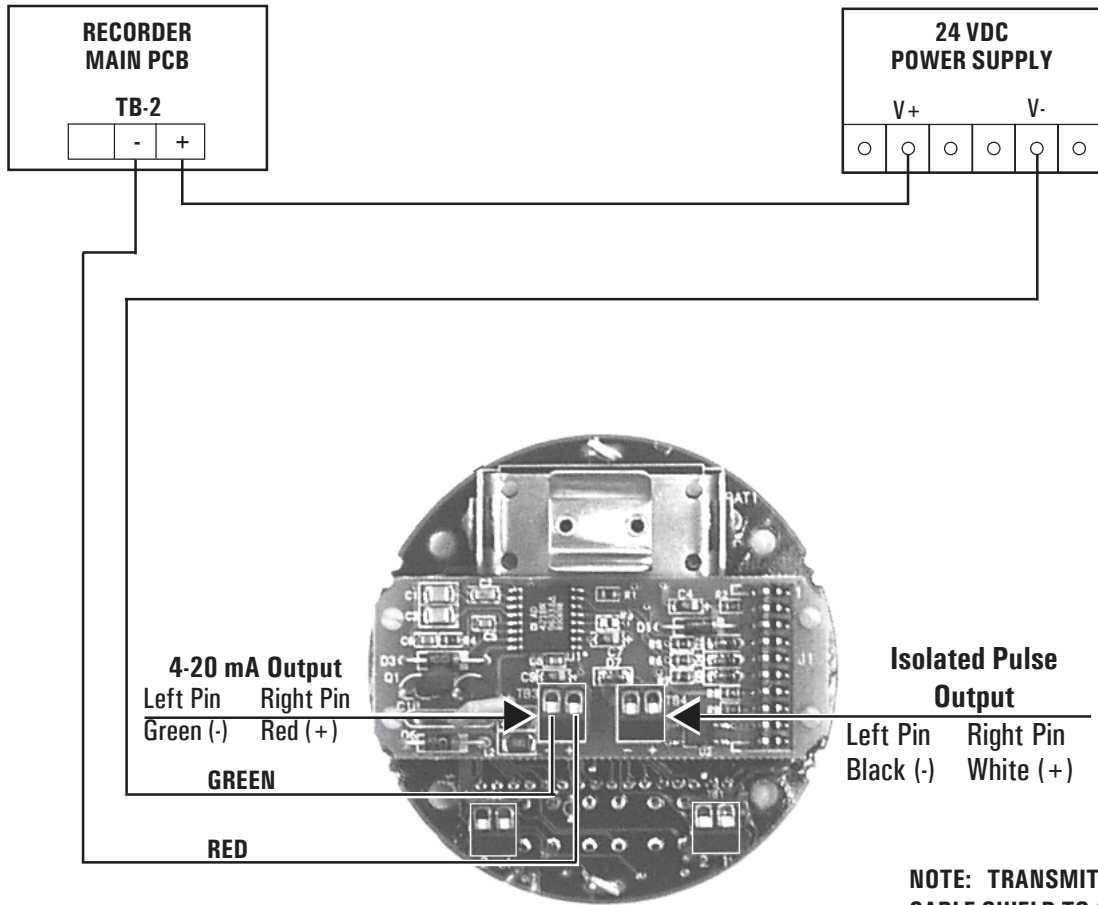

WIRING DIAGRAM FOR TR28-2 TO IN48
FOR RECORDERS SOLD AFTER 05/93
FROM TRANSMITTER RECEIVING POWER FROM RECORDER

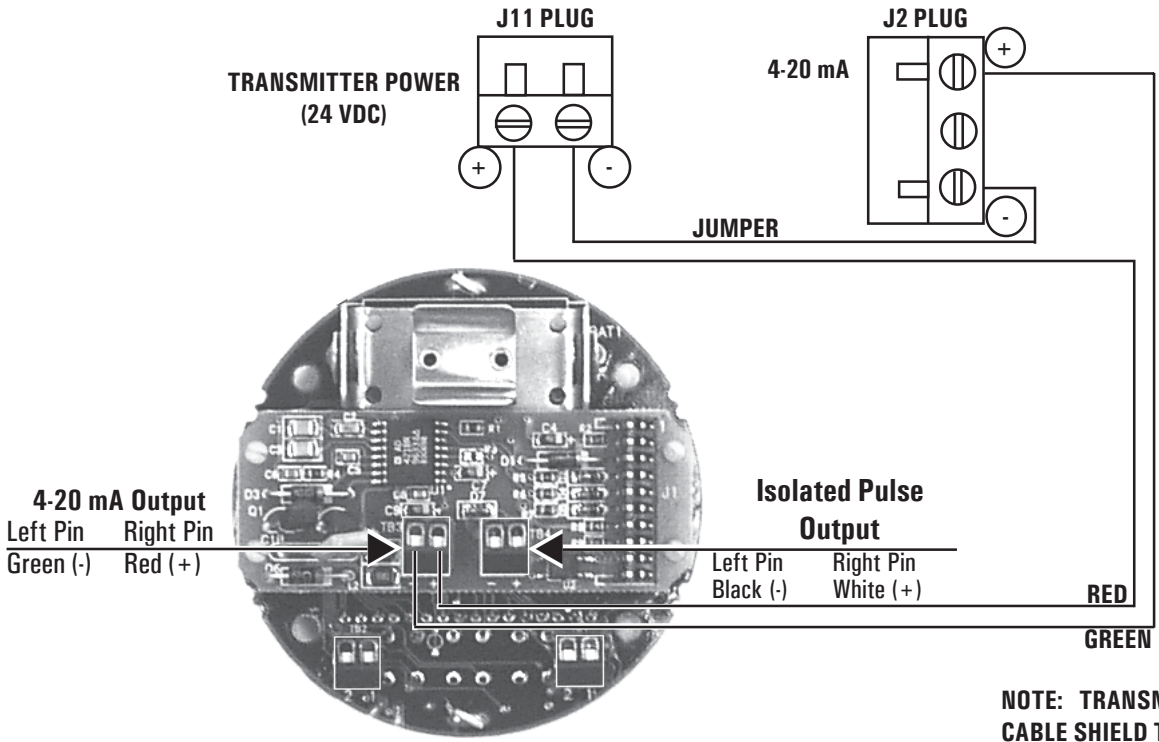

**DIGITAL INDICATOR - TOTALIZER - TRANSMITTER
MODEL TR28-2
PARTS LIST**

No.	QTY	Part Number	Description
1	1	5-4316-D-2	Digital Indicator-Totalizer Bonnet Assembly
2	1	1-1551-38	O-ring, Digital Indicator-Totalizer Bonnet
3	4	1-1115-10-10B	Screw, Bonnet Mounting (each)
4	1	5-TR28-2	Digital Indicator-Totalizer Assembly (Items 5 to 9)
5	1	3-1910-28-2	Digital Indicator Totalizer
6	1	1-1783-8	Battery (each)
8	1	1-4318-5	Base Cup
9	1	1-1551-17	O-ring, Base Cup
10	1	4-4141-1	Base Assembly
11	4	1-1115-10-10B	Screw, Bonnet Mounting (each)
12	1	1-1551-18	O-ring, Mounting Base
13	1	3-1701-4	Cable Assembly, 4 lead
14	1	1-1711-5	Water Tight Connector

When ordering replacement parts, please specify: • Meter Size • Meter Model • Meter Serial Number
 Contact Factory For Pricing.

DIGITAL INDICATOR - TOTALIZER - TRANSMITTER MODEL TR28-2 FOR ELECTRONIC PROPELLER METERS

