

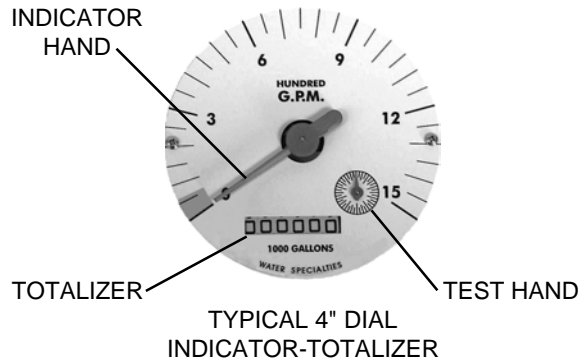

**MODEL LP22**  
 150 psi STRAP-ON SADDLE METER  
 SEALED METER MECHANISM - MAGNETIC DRIVE  
 CAST STRAP-ON SADDLE  
 INDICATOR-TOTALIZER  
 4" SIZE



#### DESCRIPTION

**MODEL LP22 STRAP-ON SADDLE METERS** are designed for irrigation or other low pressure service up to 150 PSI working pressure. The strap-on design permits installation on many types of pipe material (3/16" PVC wall minimum). It is necessary upon ordering to furnish the I.D. dimension of the pipe the meter is to be mounted on, for calibration purposes. The pipe O.D. dimension must be 4.50" for proper sealing of the saddle to the pipe.

**INSTALLATION** is made by cutting a hole in the existing pipe line and then attaching the meter securely to the line. U-bolts for attaching the meter saddle to the line are furnished with each meter. The meter can be installed horizontally, or inclined on suction or discharge lines. The meter must have a full flow of liquid for proper accuracy. Valves, fittings, or other obstructions that tend to set up flow disturbances should be a minimum of ten pipe diameters upstream and two pipe diameters downstream from the meter. Installations with less than ten pipe diameters of straight pipe require straightening vanes. Meters with straightening vanes require at least five pipe diameters upstream and two pipe diameters downstream.

**PROPELLER** is magnetically coupled with the drive mechanism through the sealed oil filled gearbox. This completely eliminates water entering the meter assembly, as well as the need for any packing gland. The propeller is a conical shaped three bladed propeller, injection molded of thermoplastic material resistant to normal water corrosion and deformity due to high flow velocities.

**BEARING** in propeller is a water lubricated ceramic sleeve and spindle bearing system with a ceramic/stainless steel spindle. Dual ceramic thrust bearings, standard on all meters, handle flows in both forward and reverse directions. The bearing design promotes extended periods of maintenance free propeller operation. Bearings within the sealed meter mechanism are shielded precision stainless steel bearings and are factory lubricated for the life of the meter.

**INDICATOR-TOTALIZER** is mechanically driven by the meter mechanism and features a full 4" diameter, 250 degree sweep dial with a six digit, straight reading type totalizer and sweep test hand. The indicator drive mechanism is temperature compensated so the indicator will be accurate at all points on the dial when operated between 32° and 140° F. The indicator dial can be furnished in GPM, CFS, MGD or any standard liquid measuring units with choice of standard totalizer measuring units. The bonnet, with padlock hasp, is o-ring sealed to the meter head.

**CHANGE GEARS** may be easily exchanged in the field when changing the dial, or when recalibrating for different pipe sizes. It is not necessary to remove pressure from the line for these changes.

**O-RING SEALS** are used at the meter head and all points where seals are required, making the meter mechanism completely immune to any of the corrosive effects of atmospheric moisture or the liquids measured by the meter assembly.

#### SPECIFICATIONS

**ACCURACY** plus or minus 2% of actual flow within the range specified for each meter size.

**PRESSURE RANGE** up to 150 PSI maximum working pressure.

**TEMPERATURE RANGE** 140° F Maximum. Consult factory for special construction for higher temperatures.

**MINIMUM FLOWS** as shown for each meter size and construction are required for accurate registration. See flow chart. NOTE: Minimum flow will be higher when auxiliary equipment is added.

**MAXIMUM FLOWS** as shown for each meter size and construction are rated for continuous operation. See flow chart.

**INTERMITTENT FLOWS** as shown for each meter size are rated for 10% to 15% of the total time the meter is operating. Consult factory for High Velocity construction when intermittent flows are higher than shown on flow chart and/or when longer operating periods are required.

**MATERIALS** used in construction are chosen to minimize the corrosive effects of the liquids measured by the meter assembly.

MAGNETS - permanent ceramic type

INTERIOR BEARINGS - factory lubricated

PROPELLER BEARING - ceramic sleeve type

PROPELLER SPINDLE - ceramic coated stainless steel

PROPELLER - injection molded thermoplastic

GEARBOX - cast bronze

SEPARATOR - stainless steel

SHAFTS AND BOLTS - stainless steel

SADDLE - fusion epoxy coated ductile iron

U-BOLTS - electro-galvanized dichromate sealed 101 B steel

**OPTIONAL EQUIPMENT** A meter mounted Fwd. & Rev. Totalizer, Totalizer Extensions, and a wide range of controls and instruments for indicating, totalizing, and recording flow data for each meter. Special constructions and materials are available upon request.

**ORDERING INFO** must be specified by the customer and should include minimum and maximum flow ranges, the temperature of the meter environment, the totalizer dial units required, the type of materials/construction needed and optional equipment desired.

**MODEL LP22**  
 150 psi STRAP-ON SADDLE METER  
 SEALED METER MECHANISM - MAGNETIC DRIVE  
 CAST STRAP-ON SADDLE  
 INDICATOR-TOTALIZER  
 4" SIZE

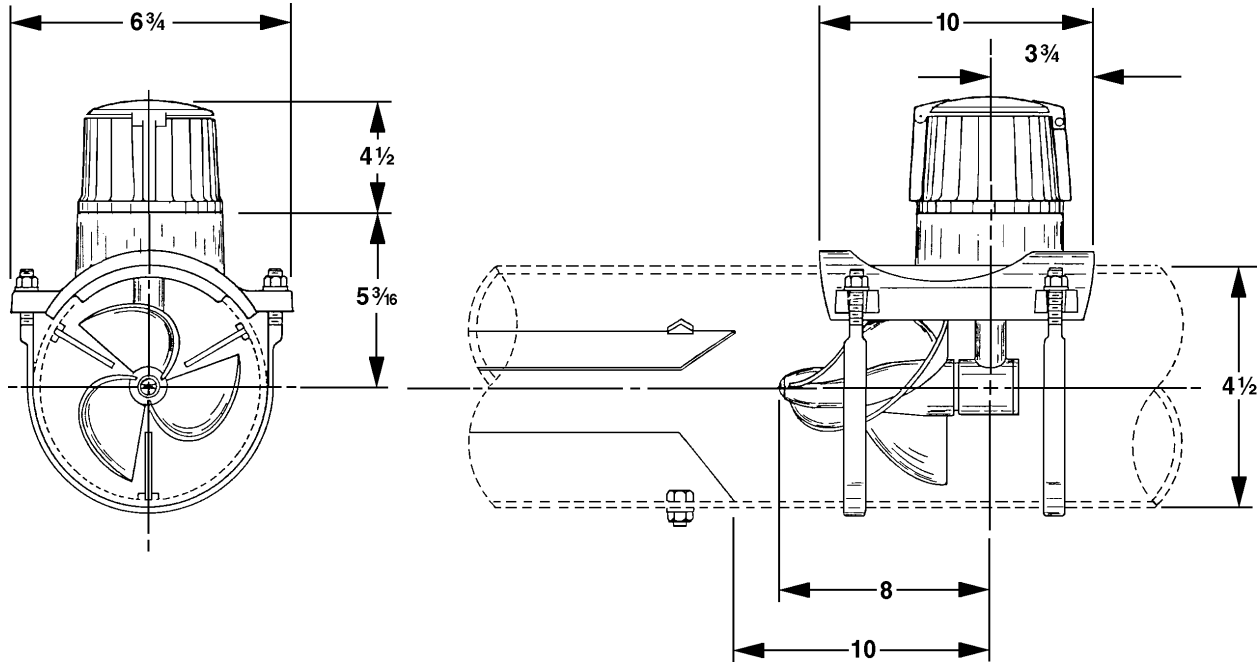

**NOTE: PLEASE SPECIFY PIPE I.D.**

METER & PIPE SIZE	FLOW RANGES, GPM			SHIPPING WEIGHT POUNDS
	MIN.	MAX.	INT.	
4	80	500	700	28



Visit our Website: [www.mccrometer.com](http://www.mccrometer.com)  
 E-Mail: [info@mccrometer.com](mailto:info@mccrometer.com)

3255 WEST STETSON AVENUE • HEMET, CALIFORNIA 92545-7799 USA  
 TEL: 951-652-6811 • FAX: 951-652-3078

Copyright © 2005 McCrometer. All printed material should not be changed or altered without permission of McCrometer. The published technical data and instructions are subject to change without notice. Contact your McCrometer representative for current technical data and instructions.