

**MODEL MLI1X-D**

150 psi REPLACEMENT METER HEAD ASSEMBLY
SOLID STATE ELECTRONIC PROPELLER METER
DIGITAL INDICATOR - TOTALIZER
SIZES 6" thru 72"

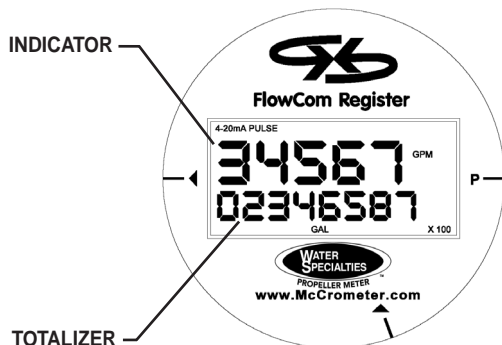

TYPICAL
DIGITAL INDICATOR-TOTALIZER

**DESCRIPTION**

MODEL MLI1X-D METER HEAD ASSEMBLIES are manufactured to the highest standards. Materials used on all meters and flow ranges for the low velocity meter meet, or exceed, AWWA standard C704-02. The bolt-on design permits use in a wide range of existing applications with up to 150 psi working pressure. It is necessary, upon ordering, to furnish the I.D. dimension of the pipe the meter is to be mounted on for calibration purposes, and the saddle dimensions from the back of the data sheet. It may be necessary to modify or remove the existing straightening vanes to allow proper clearance for Water Specialties three bladed propeller (see propeller dimension on back of data sheet).

INSTALLATION is made by bolting the meter head assembly to the existing saddle or meter tube. The meter can be installed horizontally, or inclined, on suction or discharge lines. The meter must have a full flow of liquid for proper accuracy. Fully opened gate valves, fittings or other obstructions that tend to set up flow disturbances should be a minimum of ten pipe diameters upstream and two pipe diameters downstream from the meter. Installations with less than ten pipe diameters of straight pipe require straightening vanes. Meters with straightening vanes require at least five pipe diameters upstream and two pipe diameters downstream of the meter. An optional kit of adapters and up to 100 feet of cable is available to locate the indicator-totalizer at remote locations.

PROPELLER is magnetically coupled with the electronic sensor through the sealed gearbox. This completely eliminates water entering the meter assembly, and eliminates all moving parts except for the propeller. The propeller is a conical shaped three bladed propeller, injection molded of thermoplastic material resistant to normal water corrosion and deformity due to high flow velocities.

BEARING in propeller is a water lubricated ceramic sleeve and spindle bearing system with a ceramic/stainless steel spindle. Dual ceramic thrust bearings, standard on all meters, handle flows in both forward and reverse directions. The bearing design promotes extended periods of maintenance free propeller operation.

DIGITAL INDICATOR-TOTALIZER has a non-volatile EEPROM memory to store totalizer count (updated hourly while running). Features a large two line display. Five digit top line indicates flow rate, and eight digit bottom line provides volumetric flow data. Indicator is available in 22 different units, including GPM, CFS, MGD. Totalizer is available in 20 different units, including Gallons, AF, CF. Units of measurement are user-selectable. Battery life is 6 -10 years. Housing is NEMA 4X rated.

Available with optional 4-20mA and/or pulse output.

SPECIFICATIONS

ACCURACY	Plus or minus 2% of actual flow within the range specified for each meter size.
PRESSURE RANGE	Up to 150 PSI maximum working pressure.
TEMPERATURE RANGE	140° F Maximum. Consult factory for special construction for higher temperatures.
MINIMUM FLOWS	As shown for each meter size and construction are required for accurate registration. See flow chart.
MAXIMUM FLOWS	As shown for each meter size and construction are rated for continuous operation. See flow chart.
INTERMITTENT FLOWS	As shown for each meter size are rated for 10% to 15% of the total time the meter is operating. Consult factory for High Velocity construction when intermittent flows are higher than shown on flow chart and/or when longer operating periods are required.
MATERIALS	Used in construction are chosen to minimize the corrosive effects of the liquids measured by the meter assembly. PROPELLER MAGNET - permanent ceramic type PROPELLER BEARING - ceramic sleeve type PROPELLER SPINDLE - ceramic sleeve/stainless steel PROPELLER - injection molded thermoplastic GEARBOX - cast bronze SEPARATOR - stainless steel METER HEAD BOLTS - stainless steel (3" - 20") plated steel (24" - 72") METER HEAD - cast iron or fabricated steel, NSF approved, fusion epoxy coated.
OPTIONAL EQUIPMENT	Remote mounting kit with up to 100 feet of cable, totalizer extensions, digital transmitter, and a wide range of controls and instruments for indicating, totalizing and recording flow data for each meter. Special constructions and materials are available upon request.
ORDERING INFO	Must be specified by the customer and includes: Meter size, model number and serial number of the meter it is replacing Minimum & maximum flow ranges Temperature of meter environment Indicator scale & units Totalizer dial units Type of materials and construction Optional equipment desired

MODEL MLI1X-D

150 psi REPLACEMENT METER HEAD ASSEMBLY
 SOLID STATE ELECTRONIC PROPELLER METER
 DIGITAL INDICATOR - TOTALIZER
 SIZES 6" thru 72"

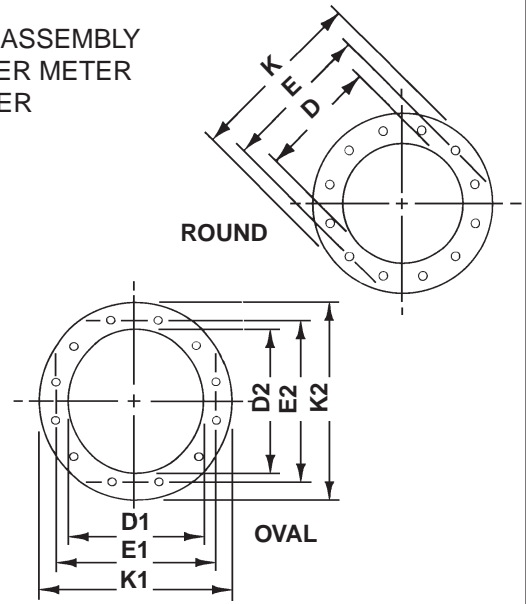
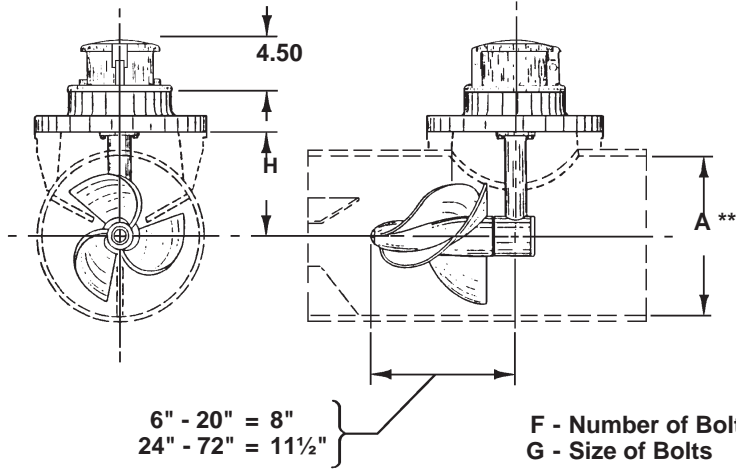

** PLEASE SPECIFY
 PIPE I.D. AND O.D.

NOTE: Existing straightening vanes may require modification or removal to allow proper clearance for Water Specialties three bladed propeller (see propeller dimension).

METER & PIPE SIZE	FLOW RANGES, GPM		DIMENSIONS (Customer Supplied Data)							EST SHIPPING WEIGHT POUNDS
	STANDARD CONSTRUCTION MIN. - MAX. - INT.	HIGH VELOCITY CONSTRUCTION MIN. - MAX.	A	(D1,D2) D	(E1,E2) E	F	G	H	K	
6	120-1200-1500	300-1500								35
8	150-1500-2000	400-2500								35
10	180-2000-3000	500-3500								45
12	200-3000-3500	800-5000								50
14	300-4000-4500	1000-6000								55
16	400-5000-6000	1200-7500								55
18	700-6000-7500	1500-9000								55
20	850-8000-9000	2000-12000								55
24	1000-10000-13500	3000-15000								190
30	1800-15000-21000	4000-25000								190
36	2000-20000-30000	5000-35000								190
42	3000-30000-40000	6000-50000								365
48	5500-35000-50000	7000-60000								365
54	6500-45000-55000	8000-65000								365
60	7500-60000-80000	10000-90000								365
66	8500-75000-95000	12000-105000								365
72	9500-90000-115000	15000-125000								365

Standard construction will be supplied for all main line meters unless special flow range, materials, or construction are required.



www.mccrometer.com

3255 WEST STETSON AVENUE • HEMET, CALIFORNIA 92545 USA
 TEL: 951-652-6811 • FAX: 951-652-3078

Copyright © 2003-2007 McCrometer. All printed material should not be changed or altered without permission of McCrometer. The published technical data and instructions are subject to change without notice. Contact your McCrometer representative for current technical data and instructions.