

### MODEL M1400 LARGE-LINE, BOLT-ON SADDLE FLOWMETER

#### DESCRIPTION

Model M1400 Bolt-On Saddle Flowmeters are manufactured to comply with the applicable provisions of the American Water Works Association Standard No. C704-02 and latest revisions for propeller type flowmeters. The M1400 features a fabricated, epoxy-coated, carbon steel saddle with McCrometer's unique drive and register design. The steel saddle eliminates the fatigue-related breakage common to cast iron and aluminum saddles and provides unsurpassed corrosion protection. Fabricated steel construction offers the additional advantage of being flexible enough to conform to out-of-true pipe. As with all McCrometer propeller flowmeters, standard features include a magnetically coupled drive, instantaneous flowrate indicator and straight reading, six-digit totalizer.

Impellers are manufactured of high-impact plastic, capable of retaining their shape and accuracy over the life of the meter. Each impeller is individually calibrated at the factory to accommodate the use of any standard McCrometer register, and since no change gears are necessary, the M1400 can be field-serviced without the need for factory

recalibration. Factory lubricated, stainless steel bearings are used to support the impeller shaft. The sealed bearing design limits the entry of materials and fluids into the bearing chamber providing maximum bearing protection.

The instantaneous flowrate indicator is standard and available in gallons per minute, cubic feet per second, liters per second and other units. The register is driven by a flexible steel cable encased within a protective vinyl liner. The register housing protects both the register and cable drive system from moisture while allowing clear reading of the flowrate indicator and totalizer.

#### INSTALLATION

Standard installation is horizontal mount. If the meter is to be mounted in the vertical position, please advise the factory. A straight run of full pipe the length of ten pipe diameters upstream and two diameters downstream of the meter is recommended for meters without straightening vanes. Meters with optional straightening vanes require at least five pipe diameters upstream and two diameters downstream of the meter.



The McCrometer Propeller flowmeter comes with a standard instantaneous flowrate indicator and straight-reading totalizer. An optional FlowCom register is also available. Typical face plates.



#### APPLICATIONS

The McCrometer propeller meter is the most widely used flowmeter for agricultural and turf irrigation measurement. Typical applications include:

- Golf course and park water management
- Gravity turnouts for underground pipelines
- Pump stations
- Water and wastewater management
- Sprinkler irrigation systems
- Drip irrigation systems

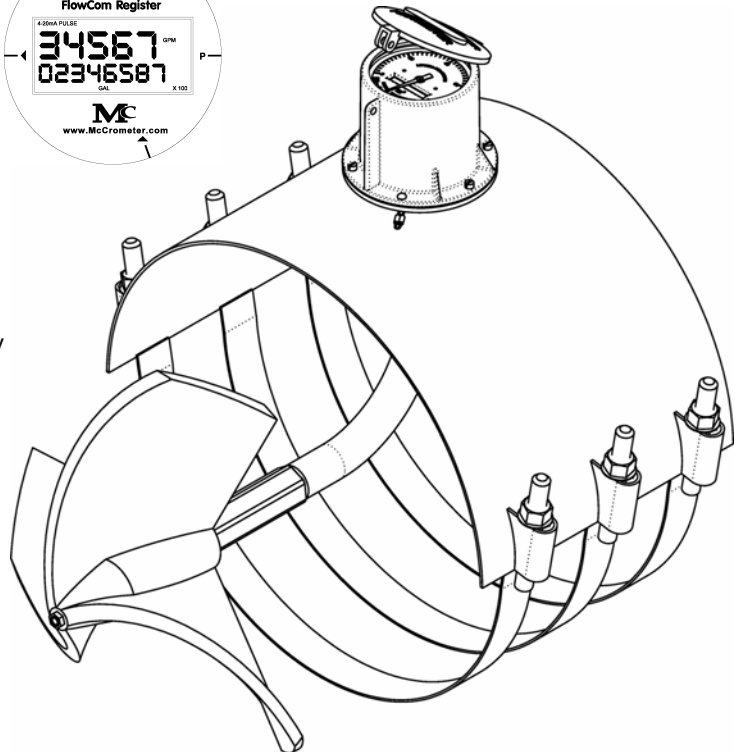

# LARGE LINE, BOLT-ON SADDLE FLOWMETER MODEL M1400

## SPECIFICATIONS

### PERFORMANCE

**ACCURACY/REPEATABILITY:**  $\pm 2\%$  of reading guaranteed throughout full range;  $\pm 1\%$  over reduced range; Repeatability 0.25% or better

**MAXIMUM TEMPERATURE:** (Standard Construction) 160°F constant

**PRESSURE RATING:** 75 psi

### MATERIALS

**BEARING ASSEMBLY:** Impeller shaft is 316 stainless steel. Ball bearings are 440C stainless steel.

**MAGNETS:** (Permanent type) Cast or sintered Alnico

**BEARING HOUSING:** Brass; 316 stainless steel optional

**SADDLE:** Epoxy-coated, carbon steel

**REGISTER:** An instantaneous flowrate indicator and six-digit straight-reading totalizer are standard. The register is hermetically sealed within a die cast aluminum case. This protective housing includes a domed acrylic lens and hinged lens cover with locking hasp.

**IMPELLER:** Impellers are manufactured of high-impact plastic, retaining their shape and accuracy over the life of the meter.

### OPTIONS

- Saddle can be constructed to fit any outside diameter pipe dimensions, including metric sizes
- Can be used on a variety of pipe materials such as steel, plastic, cast iron, cement or asbestos cement
- Register extensions
- All stainless steel bearing assembly
- "Over Run" bearing assembly for higher than normal flowrates
- Electronic propeller meter available in all sizes of this model
- A complete line of flow recording / control instrumentation
- Blank repair saddle

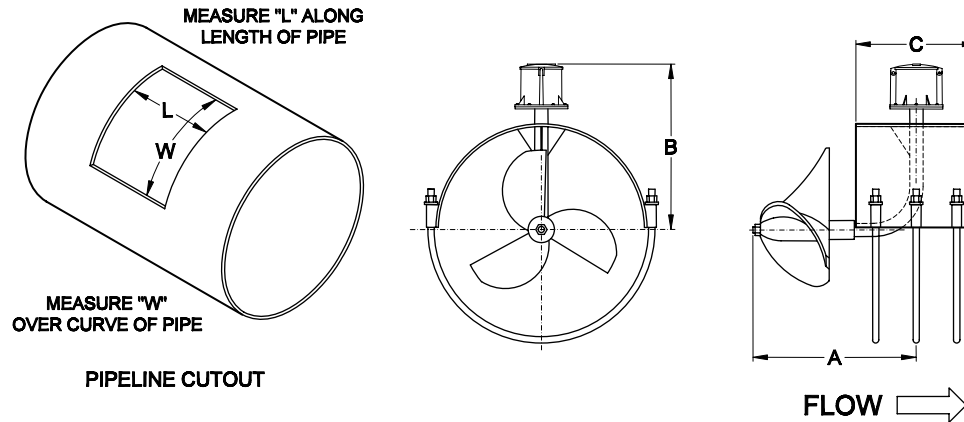

M1400	DIMENSIONS									
Meter and Nominal Pipe Size (inches)	18	20	22	24	26	28	30	32	34	36
Maximum Flow U.S. GPM	5000	6000	7000	8500	8500	12500	12500	12500	17000	17000
Minimum Flow U.S. GPM	400	475	650	700	700	1200	1200	1200	1500	1500
Standard Dial Face (GPM/Gal)	10000/ 1000	10000/ 10000	10000/ 10000	15000/ 10000	15000/ 10000	15000/ 10000	15000/ 10000	15000/ 10000	30000/ 10000	30000/ 10000
Approx. Head Loss in Inches at Max. Flow	1.5	1.25	1.0	1.0	.75	.60	.52	.50	.45	.40
Approx. Shipping Weight, lbs.	55	65	73	80	100	100	110	110	130	140
A (inches)	17	17	17	17	17	17	17	17	17	17
B (inches)	14 3/8	16 3/8	16 3/8	18 3/8	20 3/8	20 3/8	20 3/8	22 3/8	23 3/8	24 3/8
C (inches)	12	12	12	12	12	18	18	18	18	18
L (inches)	9.5	9.5	9.5	9.5	9.5	9.5	9.5	9.5	12	12
W (inches)	13.5	13.5	13.5	13.5	13.5	13.5	13.5	13.5	16	16

Large flowmeters available on special order.

McCrometer reserves the right to change design or specifications without notice.

FOR MORE INFORMATION CONTACT:



3255 West Stetson Avenue  
Hemet CA 92545 USA  
951-652-6811 / FAX 951-652-3078  
www.mccrometer.com