

MODEL MF100

DESCRIPTION

The Model MF100 is designed to provide high pressure rating and excellent meter accuracy in an inexpensive package. Model MF100 meters are manufactured to comply with the applicable provisions of the American Water Works Association Standard No. C704-02 and latest revision for propeller type flowmeters. The model MF100 is designed for a maximum continuous working pressure of up to 150 psi and is fitted with AWWA Class D flanges. The impeller and drive assembly are easily accessed through the open end of the meter tube. As with all McCrometer propeller flowmeters, standard features include a magnetically coupled drive, instantaneous flowrate indicator and straight-reading, six-digit totalizer.

Impellers are manufactured of high-impact plastic, capable of retaining their shape and accuracy over the life of the meter. Each impeller is individually calibrated at the factory to accommodate the use of any standard McCrometer register, and since no change gears are necessary, the MF100 can be field-serviced without the need for factory recalibration. Factory lubricated, stainless steel bearings

are used to support the impeller shaft. The sealed bearing design limits the entry of materials and fluids into the bearing chamber providing maximum bearing protection.

An instantaneous flowrate indicator is standard and available in gallons per minute, cubic feet per second, liters per second and other units. The register is driven by a flexible steel cable encased within a protective vinyl liner. The register housing protects both the register and cable drive system from moisture while allowing clear reading of the flowrate indicator and totalizer.

INSTALLATION

Standard installation is horizontal mount. If the meter is to be mounted in the vertical position, please advise the factory. A straight run of full pipe the length of ten pipe diameters upstream and two diameters downstream of the meter is recommended for meters without straightening vanes. Meters with optional straightening vanes require at least five pipe diameters upstream and two diameters downstream of the meter.



The McCrometer Propeller flowmeter comes with a standard instantaneous flowrate indicator and straight-reading totalizer. An optional FlowCom register is also available. Typical face plates.

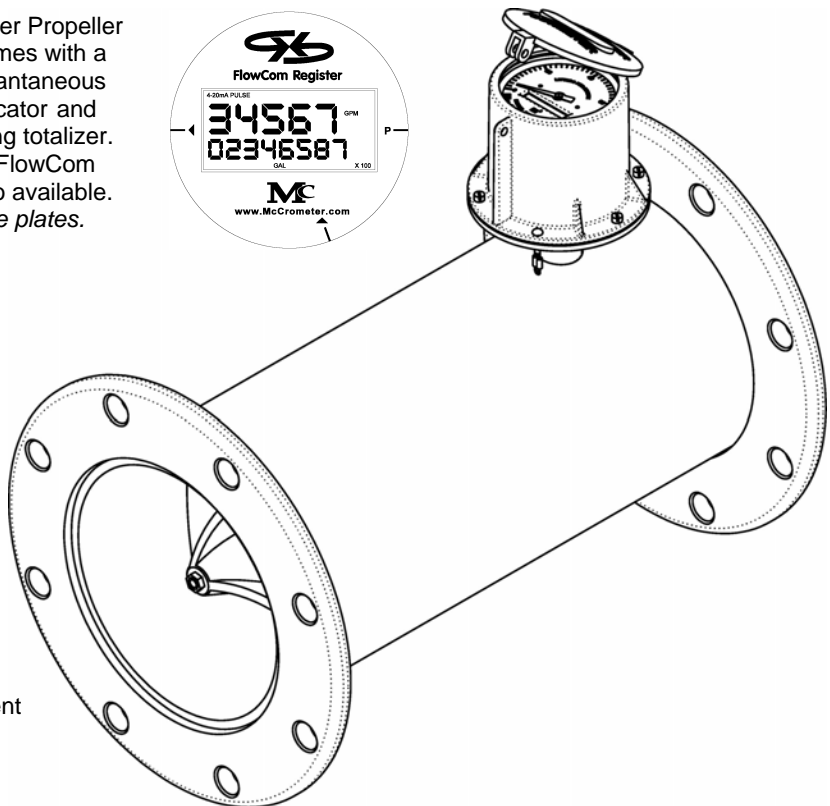
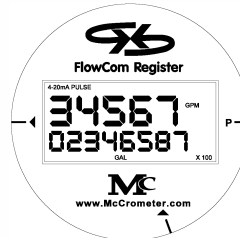

APPLICATIONS

- Center pivot systems
- Sprinkler irrigation systems
- Drip irrigation systems
- Golf course and park water management
- Commercial nurseries
- Water and wastewater management

FLANGED END FLOWMETER MODEL MF100

SPECIFICATIONS

PERFORMANCE

ACCURACY/REPEATABILITY: ±2% of reading guaranteed throughout full range. ±1% over reduced range. Repeatability 0.25% or better.

MAXIMUM TEMPERATURE: (Standard Construction) 160°F constant.

PRESSURE RATING: 150 psi

MATERIALS

BEARING ASSEMBLY: Impeller shaft is 316 stainless steel. Ball bearings are 440C stainless steel.

MAGNETS: (Permanent type) Cast or sintered alnico

BEARING HOUSING: Brass; Stainless Steel optional
REGISTER: An instantaneous flowrate indicator and six-digit straight-reading totalizer are standard. The register is hermetically sealed within a die cast aluminum case. This protective housing includes a domed acrylic lens and hinged lens cover with locking hasp.

IMPELLER: Impellers are manufactured of high-impact plastic, retaining their shape and accuracy over the life of the meter. High temperature impeller is optional.

FLOW TUBE: Fusion-bonded epoxy-coated carbon steel.

OPTIONS

- Forward/reverse flow measurement
- Register extensions
- All stainless steel construction
- High temperature construction
- "Over Run" bearing assembly for higher than normal flowrates
- A complete line of flow recording/control instrumentation
- Flow straightening vanes
- Certified calibration test results

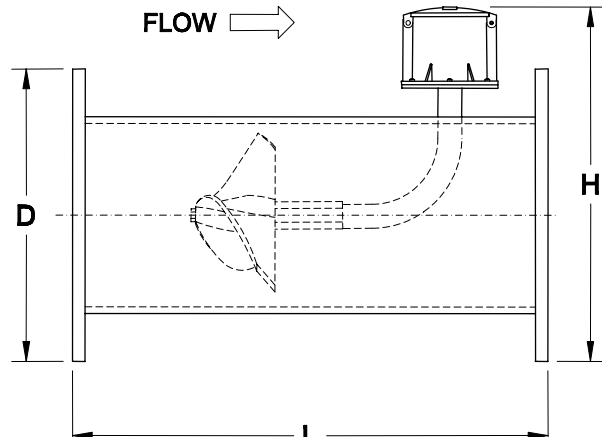
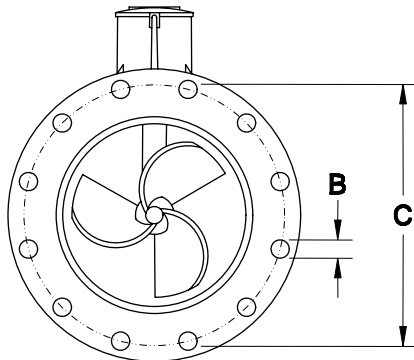

MF100	DIMENSIONS							
Meter and Nominal Pipe Size (inches)	2	2 1/2	3	4	6	8	10	12
Maximum Flow U.S. GPM	250	250	250	600	1200	1500	1800	2500
Minimum Flow U.S. GPM	40	40	40	50	90	100	125	150
Standard Dial Face (GPM/GAL)	250/ 10	250/ 10	250/ 10	800/ 100	1300/ 100	2500/ 100	3000/ 1000	4000/ 1000
Head Loss in Inches at Max. Flow	29.50	29.50	29.50	23.00	17.00	6.75	3.75	2.75
Shipping Weight, lbs.	40	40	40	50	60	102	157	176
B (inches)	3/4	3/4	3/4	3/4	7/8	7/8	1	1
C (inches)	4 3/4	5 1/2	6	7 1/2	9 1/2	11 3/4	14 1/4	17
D (inches)	6	7	7 1/2	9	11	13 1/2	16	19
H (inches)	12.16	12.66	12.91	13.66	16.03	17.28	22.53	24.03
L (inches)	13	13	13	20	20	20	20	20
No. of Bolts Per Flange	4	4	4	8	8	8	12	12

Larger flowmeters on special order.

McCrometer reserves the right to change design or specification without notice.

FOR MORE INFORMATION CONTACT: