

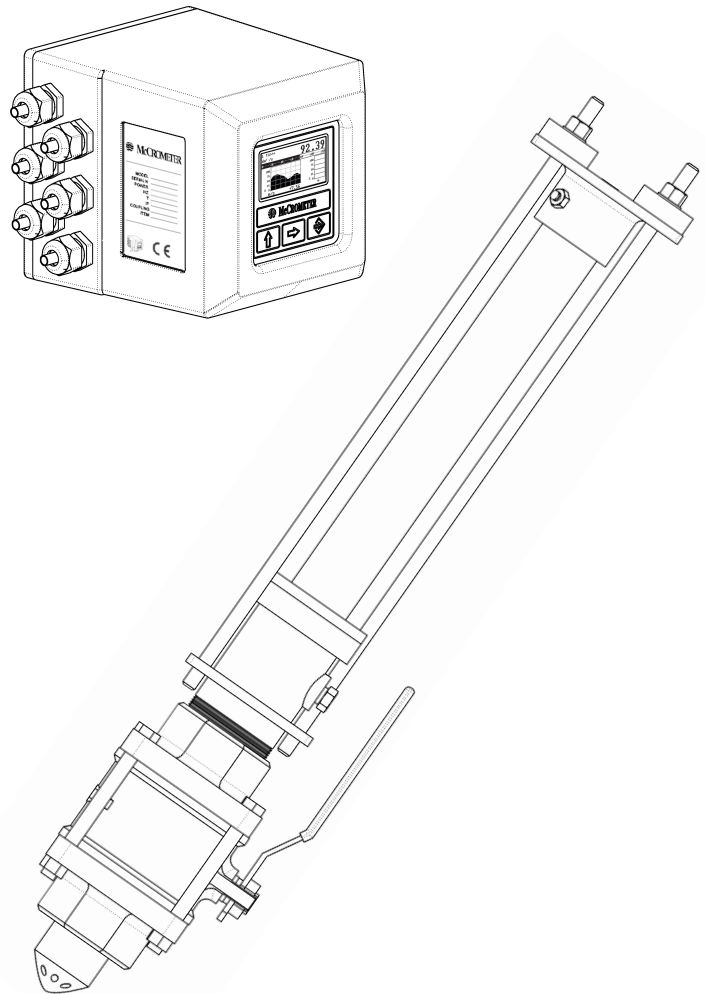

Model 282L Single Point Insertion Electromagnetic Flow Meter 2" Sensor

Suggested Specifications
24510-79 Rev. 1.3
July, 2010



Copyright © 2001-2010 McCrometer, Inc. All printed material should not be changed or altered without permission of McCrometer. Any published technical data and instructions are subject to change without notice. Contact your McCrometer representative for current technical data and instructions.



3255 WEST STETSON AVENUE • HEMET, CALIFORNIA 92545 USA
TEL: 951-652-6811 • 800-220-2279 • FAX: 951-652-3078 Printed In The U.S.A.
Lit. # 24510-79 Rev. 1.3/07-10

SPI Mag™ Model 282L 2" Suggested Specifications

GENERAL

The flow meter shall consist of two components: an electromagnetic sensor and a converter. The electromagnetic sensor shall be capable of operating in pipe diameters from 6 to 96 inches. The flow meter shall determine the volumetric flow rate by means of the Continuity Equation where flow rate "Q" equals mean velocity "V" times cross sectional area "A" ($Q = V \times A$). The velocity measurement must be taken at a known location, then, through empirically established equations, the sensed velocity will be converted to a mean velocity. The meter shall be equivalent to the SPI Mag Model 282L electromagnetic flow meter as manufactured by McCrometer, Inc., in Hemet, California, or approved equal.

CONVERTER

The flow meter converter shall be microprocessor based with a keypad for instrument setup and LCD displays for totalized flow, flow rate, engineering units and velocity or totalized flow. The converter shall power the flow-sensing element and provide a galvanically isolated 4-20mA output for flow, and one flow proportional or frequency output (transistor type) for flow rate or for external totalizer. It shall be possible, in the test mode, to easily set the transmitter outputs to any desired value within their range. The 4-20mA scaling, time constant, pipe size, flow proportional output, engineering units and test mode values shall be easily set via the keypad and display. Two separate, fully programmable alarm outputs shall be provided to indicate high/low flow rates, empty pipe, fault conditions, reverse flow and over-range conditions. The transmitter shall periodically perform self-diagnostics and display any resulting error messages. All setup data and totalizer values may be protected by a password.

SENSOR

The flow-sensing element shall be of an electromagnetic single point type design and factory calibrated to traceable standards, such as NIST. The sensor shall be made of a polyurethane with pure carbon or stainless steel electrodes exposed to flow. Installation of the sensor shall be accomplished under flowing conditions through a 2-inch valve, with final location being located near the inside wall of the flow conduit. To eliminate erroneous readings due to pipe wall effects, the sensor must have its electrodes located at least 3/16" from pipe wall and be designed with a curved tip shape, so as not to collect debris while in the operating position. Flat tipped or Doppler sensors shall not be acceptable.

SENSOR CABLE

The sensor cable is 20 feet of multi-conductor, abrasive resistant, jacketed cable flexible to -40°F. The sensor cable shall be permanently bonded to the sensor. Additional sensor cable, up to 300 feet, shall be available as an option.

MOUNTING HARDWARE

A PVC insertion tube and restraining rods shall be provided for the smooth installation and operation of the velocity sensor. The PVC insertion tube and rods shall be of sufficient length to allow a full profile of the flow conduit. The PVC hardware shall be rated for 150 PSI @ 105° F. Hardware must allow sensor to be secured by bolts when sensor is being inserted and retracted. A stainless steel compression seal with neoprene rubber exposed to flow shall also be supplied.

SPECIFICATIONS

MEASUREMENT

Volumetric flow in filled flow conduits 2" (50mm) to 96" (2440 mm) in diameter utilizing insertable velocity sensor. Flow indication in English std. or Metric units.

FLOW MEASUREMENT

Method: Electromagnetic

Accuracy: $\pm 2\%$ of reading ± 0.03 ft/s (± 0.009 m/s) zero stability from 0.3 to 20 ft/s (0.09 to 6 m/s) velocity range

Velocity Range: +0.3 to +30 ft/s (+0.09 to +9 m/s)

Has reverse flow indication.

CONDUCTIVITY

Minimum conductivity of 5 μ S/cm (5 μ mho/cm)

POWER REQUIREMENTS

AC: 90-265V 44-66 Hz (20W/25VA) or

DC: 10-35V at 20W.

AC or DC must be specified at time of ordering.

MATERIALS

Sensor: Polyurethane exposed to flow

2" Sensor Mounting: PVC and Stainless Steel exposed to flow. (Stainless Steel Insertion Tube Optional)

Compression Seal: Buna "N" exposed to flow.

OUTPUTS

Analog: 4-20mA 1000 Ohms galvanically isolated and fully programmable.

Pulse: 2 Pulse/Frequency/Alarm outputs programmable for high/low flow rates, percent of range, empty pipe, fault conditions, forward/reverse, polarity (normally open/close), analog over-range, pulse over-range, etc.

DUAL ALARMS

2 separate outputs: Isolated and protected transistor switch capable of sinking <250mA @ <35V. Note: Not isolated from frequency output. Fully programmable for high/low flow rates, % of range, empty-pipe, fault conditions, forward/reverse, polarity (normally open/close), analog over-range, pulse over-range, pulse cutoff, etc.

CONVERTER ENCLOSURE

IP67 Die cast aluminum enclosure

5.75" H x 5.75" W x 6.69" D

(14.6 cm H x 14.6 cm W x 17 cm D). Weight: 6.8 lbs. (3.1 kg)

ELECTRICAL CONNECTIONS

Compression gland seals for 0.125" to 0.375" dia. round cable.

ISOLATION

Galvanic separation to 50VDC between analog, pulse/alarm, and earth/ground.

STANDARDS

CE Certified (Converter only)

ENVIRONMENTAL

Pressure/Temperature Limits:

PVC Insertion Tube:

Up to 105°F (41°C) at 150 psi

Stainless Steel Insertion Tube:

Up to 160°F (71°C) at 250 psi

(McCrometer recommends the use of Stainless Steel)

Electronics: Operating and storage temperature: -4° to 140°F (-20°C to +60°C)

KEYPAD AND DISPLAY

Can be used to access and change all set-up parameters using three membrane keys and LCD display.

OPTIONS

- DC Power
- Pole mounting kit
- Sun shield
- Sensor insertion tool
- Stainless steel ID tag
- Valves
- Additional sensor cable up to 300' (for longer lengths, consult factory)