

Advanced
Differential
Pressure
Flowmeter
Technology

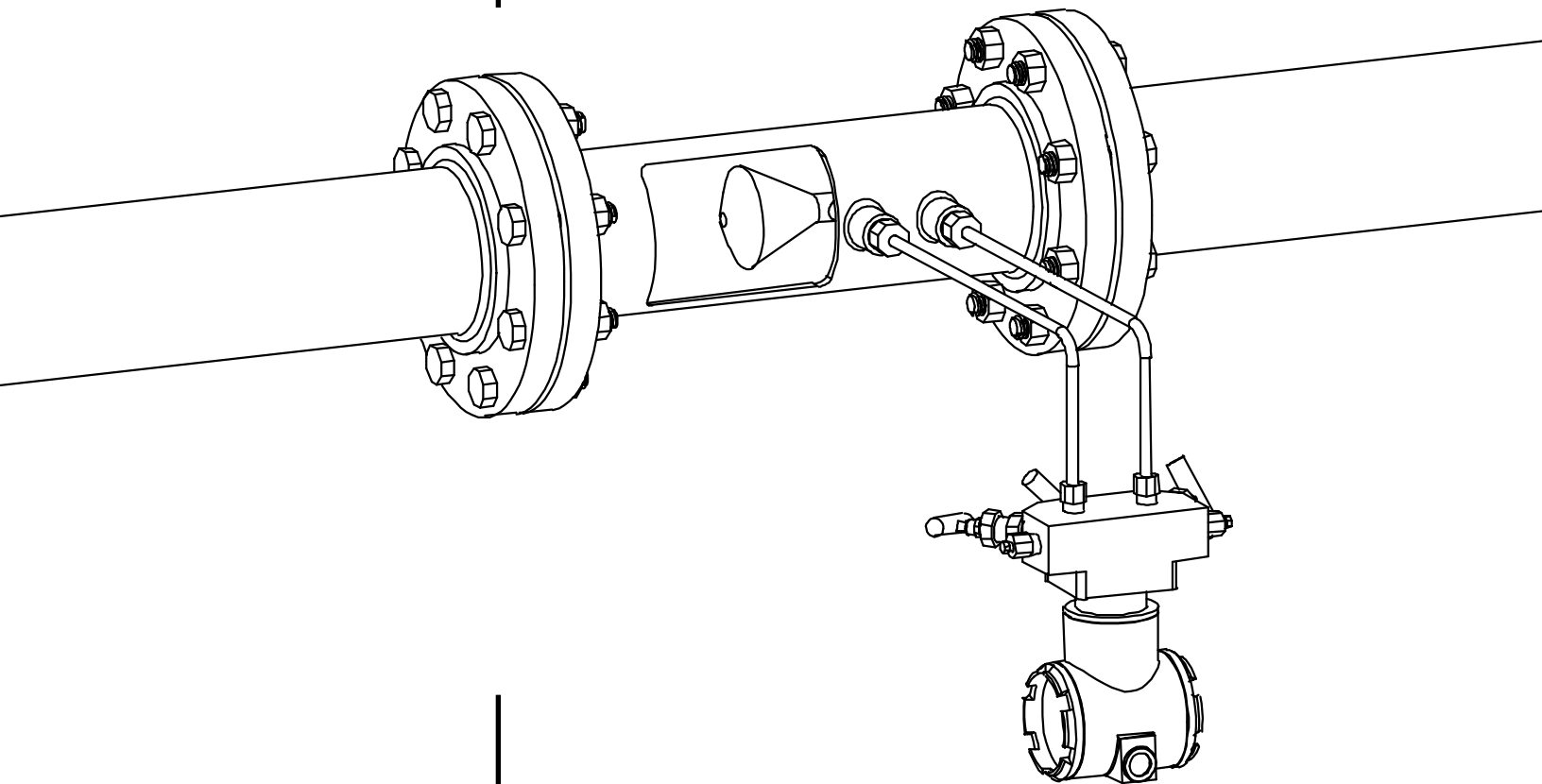
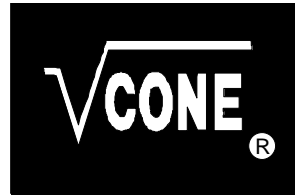

V-CONE
STEAM PLANT CASE STUDY

IDEA 95th Annual Conference & Trade Show
Seattle, Washington
June 27-30th, 2004

**The Use of a V-Cone Fuel Flow Meter to Measure the Coke Oven Gas and
Natural Gas Flow in a Combined Heat and Power Plant**

Authors:

Ann McIver, QEP
Environmental Coordinator
Citizens Thermal Energy
Indianapolis, Indiana

Dr. R.J.W. Peters
Flow Measurement Technology Manager
McCrometer
Hemet, California

Abstract:

This paper describes key aspects of the Citizens Thermal Energy district energy system in Indianapolis. It will present the requirements imposed, through the continuous emissions monitoring rules established by the Environmental Protection Agency (EPA), as delineated in 40 CFR 75. The reason for the choice of the V-Cone, which is not a fuel flow metering technology specifically addressed in the regulations, will be presented and the tests required by the EPA to enable the V-Cone to be accepted. The results of the flow tests in an independent laboratory before and after a period in service will be given.

The Use of a V-Cone Fuel Flow Meter to Measure the Coke Oven Gas and Natural Gas Flow in a Combined Heat and Power Plant

CITIZENS THERMAL ENERGY – CHP AND DISTRICT ENERGY

Citizens Gas & Coke Utility (“the Utility”) is the trade name under which the City of Indianapolis, by and through the Board of Directors for Utilities of the Department of Public Utilities, a municipal corporation of the State of Indiana, as successor trustee of a Public Charitable Trust, provides energy services to customers in and around Marion County, Indiana. Citizens Thermal Energy, a division of Citizens Gas & Coke Utility, is the owner and operator of the district energy assets acquired by the Utility in November, 2000. The assets acquired include:

- the West Street Chilled Water plant and the associated chilled water distribution system;
- Indianapolis Campus Energy, which provides chilled water to the Lilly Technology Center; and,
- the C.C. Perry K Steam Plant and associated steam distribution system.

The C.C. Perry K Steam Plant

The C.C. Perry K Steam Plant (“Perry K”) was constructed in 1893 for purposes of providing electricity to downtown Indianapolis. While the plant was originally built as an electric generating station, the plant’s principal product evolved to steam as the city of Indianapolis grew. Approximately 5.3 billion pounds of steam is produced for sale to district steam customers each year, distributed at a nominal pressure of 250 psig at 550 degrees Fahrenheit through 24 miles of underground steam lines. Approximately one-half of the steam sold to the district steam customers each year is produced from the incineration of municipal solid waste (trash) at the Indianapolis Resource Recovery Facility operated by Covanta Energy Systems.

The variety of fuels has allowed the Indianapolis steam system to provide a low-cost energy source to businesses in Indianapolis. A major pharmaceutical manufacturer utilizes the steam for electric generation and the production of chilled water, in addition to process use of the steam. The local university utilizes steam for building heat, and the five (5) hospitals located within the university campus utilize the steam for a wide variety of purposes, including sterilization and humidification. Other industrial users include a corn processing facility and an automobile fabrication plant. Hotels, office buildings and apartment buildings are also customers of the steam system, relying on the system for heating and hot water purposes.

The Perry K is situated in the heart of Indianapolis and as such must exercise great care to protect the surrounding environment. In the early 1900s, Research-Cottrell installed some of the nation’s first electrostatic precipitators on the coal-fired boilers. Precipitators are used to collect ash from the combustion gases before they are exhausted from the stacks. Modernized

and capable of meeting today's environmental standards, precipitators are still utilized on the coal-fired boilers at Perry K to remove the ash.

The Perry K plant has the capacity to produce nearly 2,000,000 pounds of steam per hour from a total of eight boilers. The normal winter peak demand on the system will be approximately 1.5 million pounds per hour of steam, which will typically occur on the coldest day of the year. The oldest operating piece of equipment in the facility is a General Electric, 17-megawatt (nominal) turbine generator which was originally installed in 1924.



Fig 1: C.C. Perry K Steam Plant, Indianapolis

Coal-fired boilers #11 and #12 were built circa 1938, #13 and #14 were built circa 1947 and #15 and #16 were built circa 1952. Two package boilers which fire #2 fuel oil, #17 and #18, were installed in the early 1970's. Table A contains specific information on the boilers at the steam plant.

In the late 1990's, boilers #11, #13 and #14 were converted from coal-fired to coke-oven gas and/or natural gas fired. The coke-oven gas is supplied under contract with Indianapolis Coke, the manufacturing Division of Citizens Gas & Coke Utility. The conversion to coke-oven gas resulted in significant reductions of emissions to the atmosphere, including reductions in sulfur dioxides and nitrogen oxides.

CTE Perry K Steam Plant

Table 1: Boiler Information

Boiler ID:	11	12	13	14	15	16	17	18
Primary Fuel	PNG ¹ - COG	Coal ²	PNG – COG	PNG - COG	Coal	Coal	#2 Fuel Oil	#2 Fuel Oil
Boiler Type	Wall Fired	Pulverized Wall Fired	Wall Fired	Wall fired	Spreader Stoker	Spreader Stoker	Package	Package
Year In-Service	1937	1937	1946	1946	1952	1952	1974	1972
Projected Retirement ³	2034	2029	2034	2034	2019	2019	2034	2034
Nameplate Operating Pressure (psig)	650	650	255	255	260	260	250	250
Operating Temperature	783 F	783 F	600 F	600 F	600 F	600 F	500 F	500 F
Nameplate Steam Flow	300 mlb/hr	300 mlb/hr	300 mlb/hr	300 mlb/hr	225 mlb/hr	225 mlb/hr	170 mlb/hr	170 mlb/hr
Design Flue Gas Exhaust Temperature	375 F	375 F	319 F	319 F	580 F	580 F	597 F	597 F
Average Thermal Efficiency (%) ⁴	85.6%	85.6%	86.1%	86.1%	78.3%	78.3%	79.9%	78.6%
Existing PM Controls		ESP			ESP ⁵	ESP		
Existing NOx Controls	LNB/FGR ⁶		LNB	LNB				
Exhausts to Stack	#3	#3	#4	#4	#1	#1	#1	#1

¹ PNG: Pipeline natural gas; COG: Coke oven gas

² The coal-fired boilers combust Indiana bituminous coal with an average heat content of 11,000 Btu/lb, 1.1% sulfur, and 6% ash.

³ Projected Retirement year assumes continued normal maintenance and capital expenditures, but it does not factor-in life extension improvement projects

⁴ Thermal Efficiency based on initial unit acceptance tests (#11 thru #16); initial unit design calcs (#17, #18)

⁵ Boilers #15 and #16 exhaust to a common ESP

⁶ LNB: Low-NOx burners; FGR: Flue gas recirculation

Fuel Supply for the Boilers

In terms of dispatching, the demands of the steam system will first be addressed with steam from the waste-to-energy facility. The combustion of coke-oven gas will be ordered next, followed then by coal, natural gas and #2 fuel oil.

In 2003, the steam system demand met by Perry K, resulted in the combustion of approximately:

- 120,000 tons of coal
- 612,000 thousand cf of natural gas
- 4,980,000 thousand cf of coke-oven gas

The Division reported just slightly more than 31,000 megawatts of gross generation to the Energy Information Administration for the 2003 reporting year.

Regulatory Requirements Related to Fuel Flow Meters

In 2002, the Indiana Department of Environmental Management completed adoption of regulations to implement the provisions of the NO_x SIP Call. These rules⁷ impose continuous monitoring requirements on the large boilers at the C.C. Perry K Steam Plant in accordance with the provisions of 40 CFR 75, Subpart H.

For the gas-fired boilers at Perry K, fuel flow metering is an option which may be utilized to determine the mass emissions of nitrogen oxides, NO_x, from the boilers, in lieu of a flue-gas volumetric flow measurement device. The fuel flowmeters installed under this option are regulated under Appendix D to Part 75 –Optional SO₂ Emissions Data Protocol for Gas-Fired and Oil-Fired Units.

These provisions outline initial certification and calibration requirements, as well as on-going quality assurance / quality control provisions. The requirement says, in part:

“For the purposes of initial certification, each fuel flowmeter used to meet the requirements of this protocol shall meet a flowmeter accuracy of 2.0 percent of the upper range value (i.e. maximum fuel flow rate measurable by the flowmeter) across the range of fuel flow rate to be measured at the unit. Flowmeter accuracy may be determined under section 2.1.5.1 of this appendix for initial certification in any of the following ways (as applicable): by design (orifice, nozzle, and venturi-type flowmeters, only) or by measurement under laboratory conditions; by the manufacturer; by an independent laboratory; or by the owner or operator.

Flowmeter accuracy may also be determined under section 2.1.5.2 of this appendix by in-line comparison against a reference flowmeter.⁸”

⁷ Title 326 Indiana Administrative Code Article 10, Chapter 4 (326 IAC 10-4)

⁸ 40 CFR 75, App. D § 2.1.5, Initial Certification Requirements for all Fuel Flowmeters

Experience had shown that for the Coke Oven Gas an orifice, nozzle or Venturi meter could be adversely affected by volatile and particulate carry over, building up in the meter, resulting in significant errors in the results. For this reason Citizens Thermal Energy decided to use the V-Cone meter which enables liquids and particulates to be driven down through the opening around the cone by the gas.

THE V-CONE FUEL FLOW METER

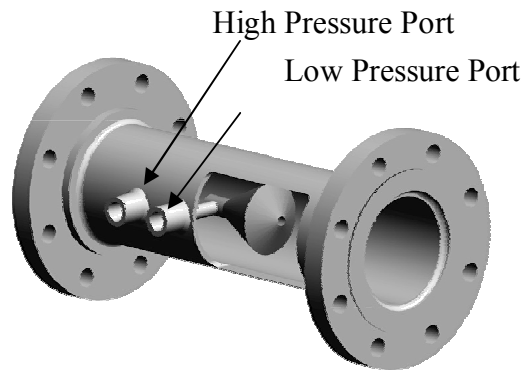

Fig. 2: “V-cone[®] flowmeter”

The V-cone[®] flowmeter has been designed to measure the flow of fluids in a closed conduit by generating a Differential Pressure as the fluid passes through the meter. The Differential Pressure is measured between an Upstream High Pressure Port and a Downstream Low Pressure port that is located in the center of a cone. This cone establishes: a differential pressure, conditions the fuel flow, and sheds vortices from it. The fuel flowmeter performs significantly better than many other meters when there is a restriction in the length of long straight pipework where a meter may be installed, and also when there is liquid or particulate associated with the gas.

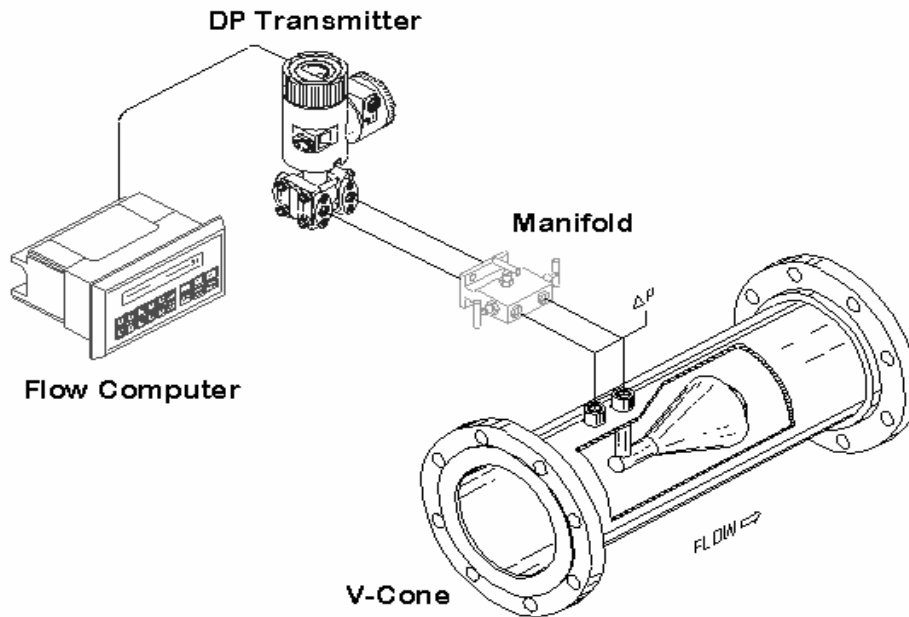

Fig 3 Complete V-Cone System

The Differential Pressure reading can be related to the flow rate from the following equation:

$$q_m = \frac{C}{\sqrt{1 - \beta^4}} A_t \sqrt{2 \rho \Delta p}$$

Where:

- q_m = Mass flowrate
- ρ = fluid density
- C = Discharge Coefficient
- β = Beta ratio
- A_t = Throat Area
- Δp = Differential Pressure

The differential pressure transducer is normally attached to the fuel flow meter through a manifold valve, as shown in figure 3. The value of C for the fuel flow meter is established by flow testing the meter.

McCrometer completes initial calibrations on the fuel flow meters in accordance with ASME MFC-9M-1988 with 1989 Errata ("Measurement of Liquid Flow in Closed Conduits by Weighing Method"). If the meter has to be tested in gas to verify the flowmeter over the flow range it could be sent to Colorado Engineering Experiment Station, Inc. ("CEESI") or Southwest Research Institute ("SWRI") and tested in accordance with ASME MFC-7M-1987 (Reaffirmed 1992), "Measurement of Gas Flow by Means of Critical Flow Venturi Nozzles".

Additionally, the fuel flow meter has been tested in accordance with API 5.7 “Testing Protocol for Differential Pressure Flow Measurement Devices” at Southwest Research Institute (SWRi) and at Utah State Water Research Laboratory. SWRi issued a final report and it is anticipated that the results will be presented at The North Sea Flow Measurement Workshop in Scotland in October, 2004.

FUEL FLOW TO LOAD RATIO REQUIREMENTS

The regulations permit the owner or operator of an affected source to extend the annual calibration requirement through the use of a “fuel flow to load” ratio determination. This provision requires the determination of a baseline ratio, calculated as a result of a baseline data collection period of 168 unit operating hours. Subsequent data is evaluated against the baseline ratio. The regulations allow the exclusion of data during periods of ramping (defined as a change in load of more than 15% from the previous hour) and data collected when the affected unit is operating in the lower 25% of the range of operation (as defined by the monitoring plan).⁹ The ratio may be defined as either the fuel flow to steam load, scfh/1000 pph steam, or as the gross heat rate, Btu/1000 pph steam.

If the fuel flow-to-load tests are performed during each fuel flowmeter QA operating quarter, the requirement for periodic quality assurance testing, or recalibration, of the fuel flow meter may be extended up to 20 calendar quarters from the previous accuracy test.¹⁰

Table 2: Summary of the V-Cone Fuel Flow Meters and Location at the Plant

<i>Meter Number</i>	<i>Boiler Number</i>	<i>Fluid</i>	<i>Initial Calibration/Installation</i>	<i>Re-calibration</i>
98-0651	11	Coke Oven Gas	1998	April, 2004
98-0654	11	Natural Gas	1998	April, 2004
98-0652	13	Coke Oven Gas	1998	2003
98-0655	13	Natural Gas	1998	2003
98-0653	14	Coke Oven Gas	1998	2003
98-0656	14	Natural Gas	1998	2003
01-0712	11	Coke Oven Gas	2001	Summer 2004
01-0713	11	Natural Gas	2001	Summer 2004

To support a request, which will be made to the U.S. EPA’s Clean Air Markets Division later in 2004, Citizens Thermal Energy has undertaken a planned calibration program to establish the stability of the V-cones over time after extended in-service periods. The following discussion and graphs present the results of these tests.

⁹ 40 CFR 75 §2.1.7, Fuel Flow-to-Load Quality Assurance Testing for Certified Fuel Flowmeters

¹⁰ 40 CFR 75 §2.1.6

RESULTS OF RECALIBRATIONS OF THE FUEL FLOW METERS

In the following series of graphs the plot is of Cd against Re, which is a normal method of presentation for flow measurement results. The following definitions and explanations may assist the reader to understand the methodology used.

Discharge Coefficient (Cd)¹¹

For a given primary element, the discharge coefficient is derived from laboratory data by ratioing the true and theoretical flow rates. The true rate is determined by weighing or volumetric collection of the fluid over a measured time interval, and the theoretical flow rate is calculated. The Discharge Coefficient is then defined as

$$C_d = \frac{\textit{True Flow Rate}}{\textit{Theoretical Flow Rate}}$$

The discharge coefficient is a dimensionless number which corrects the theoretical equation for the influence of velocity profile (Re), the assumption of no energy loss between taps, and pressure tap location. It varies with the type of Differential Pressure meter, e.g. Venturi Cd \approx 0.9, orifice \approx 0.6 and V-cone \approx 0.8.

Reynolds Number (Re)

$$\text{Re} = \frac{\rho V D}{\mu} = \frac{\textit{inertial forces}}{\textit{viscous forces}}$$

where: ρ = density

V = average flowing velocity

D = pipe diameter

μ = viscosity

The value of the Reynolds number is that it embodies the concept of flow similarity. For different fluids and for two geometrically similar pipes, the flow behaviour will be the same for equal values of Re in each pipe. It follows then that if a meter is calibrated in water, for example, it will produce the same answer in air for that Re value. The Reynolds number is a dimensionless number.

¹¹ Miller's Flow Measurement Engineering Handbook, 3rd Edition

From these definitions it follows that graphs of Re against Cd means that for any flow rate, the user can calculate the Re value for his/her application and from the curve they know what the Cd value (or correction value) will be.

Meter 98-0651 (Coke Oven Gas).

This meter was initially tested in 1998 prior to having it installed in service. It was returned to CEESI this year and was recalibrated without cleaning and the comparison graph is shown below. It is apparent that the results are well within the +/- 2% requirement of the EPA requirements over a very wide Re spread.

However it should be noted that following cleaning the results were very close to those obtain when the meter was initially calibrated 6 years previously

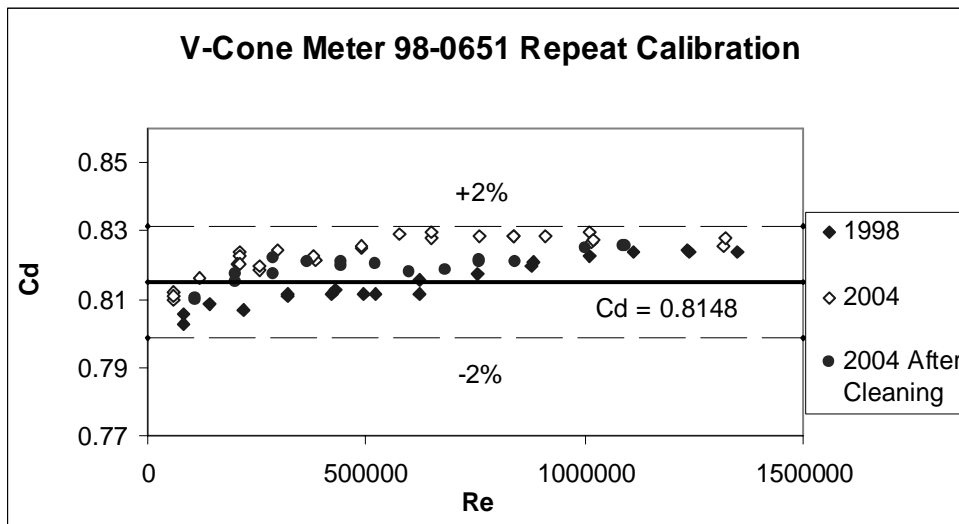

Fig 4: Flow Testing of Meter 98-0651

Meter 98-0652 (Coke Oven Gas).

This meter was initially tested in 1998 prior to installation. It was returned to CEESI last year and was recalibrated as delivered without cleaning and the comparison graph is shown below. It was then cleaned and recalibrated. The family of curves is shown below. It can be seen that even as received in a dirty condition the results were similar but offset by approximately 1.5%. Following cleaning the average difference from the initial calibration in 1998 was less than +/- 1%

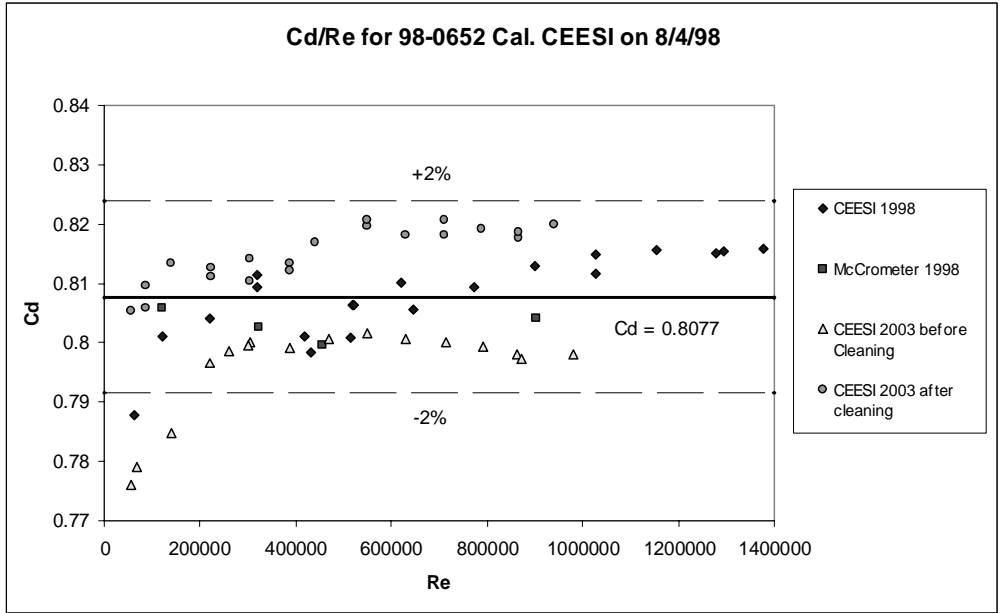

Fig 5: Flow Testing of Meter 98-0652

It should be noted that in all of the graphs the Cd value falls off at lower Re. This is a combination of the uncertainty of; the differential pressure transducer increasing as the DP reduces; the uncertainty of the lab. at low flows; and also a characteristic of the meter. If a reduction was required in the uncertainty this can be achieved by using a curve fit of Re to Cd to fit the points rather than to use a fixed single Cd value for the meter. This is given below for the meter as built and the data compared to the meter as tested in the dirty condition.

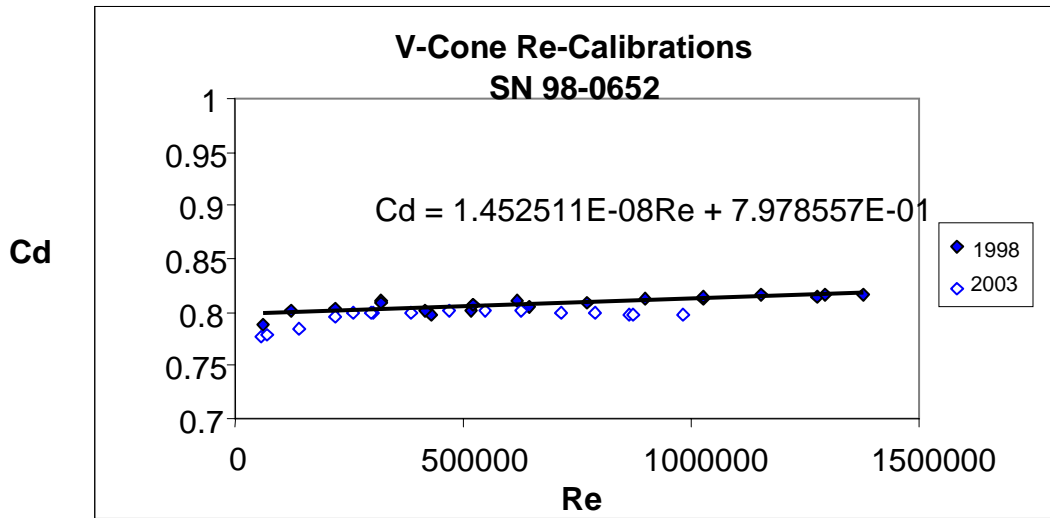

Fig 6: Flow Testing of Meter 98-0652 and the application of a linear fit to the 1998 data

Meter 98-0654 (Natural Gas).

It can be seen from the graph below that there was virtually no change in the calibration of this meter from 1998 to 2004. There is the drop off at low flows as described above. These measurements were being made with a differential pressure of 0.5" WC in 1998 and 0.7" WC in 2004 and that is a region of relatively high uncertainty for the Differential Pressure transducers.

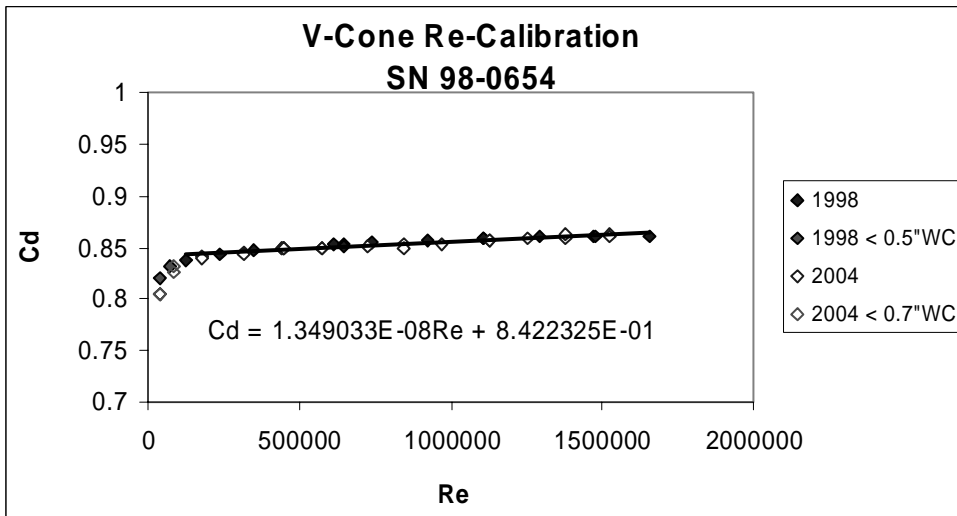
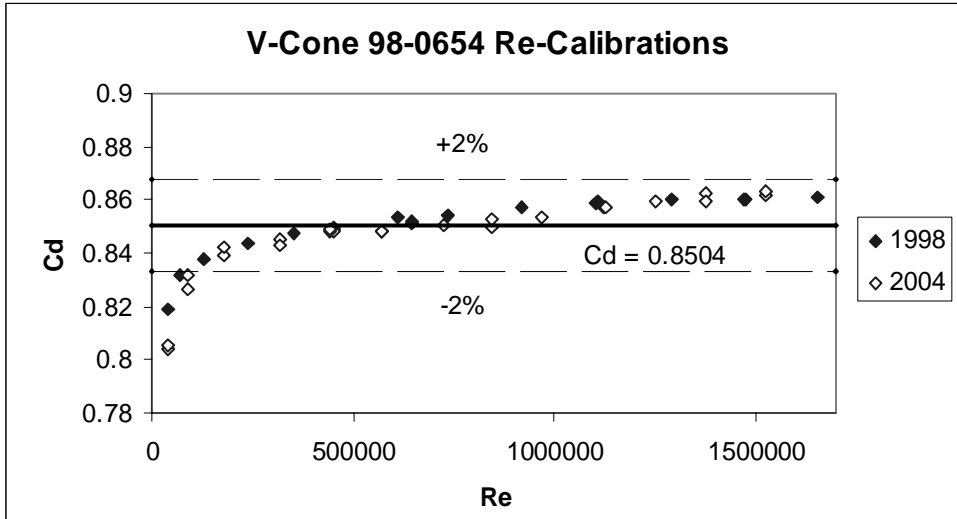

Fig 7 (upper) and Fig 8 (lower):
Flow Testing of Meter 98-0654 and the application of a linear fit to the 1998 data

Meter 98-0653 (Coke Oven Gas).

This meter was initially tested in 1998 prior to installation. It was returned to CEESI last year and was recalibrated. It can be seen that there was about a 1% shift in the results between 1998 and 2003. This meter is the poorest comparison of the meters which were retested but it would still be within the +/-2% EPA requirement

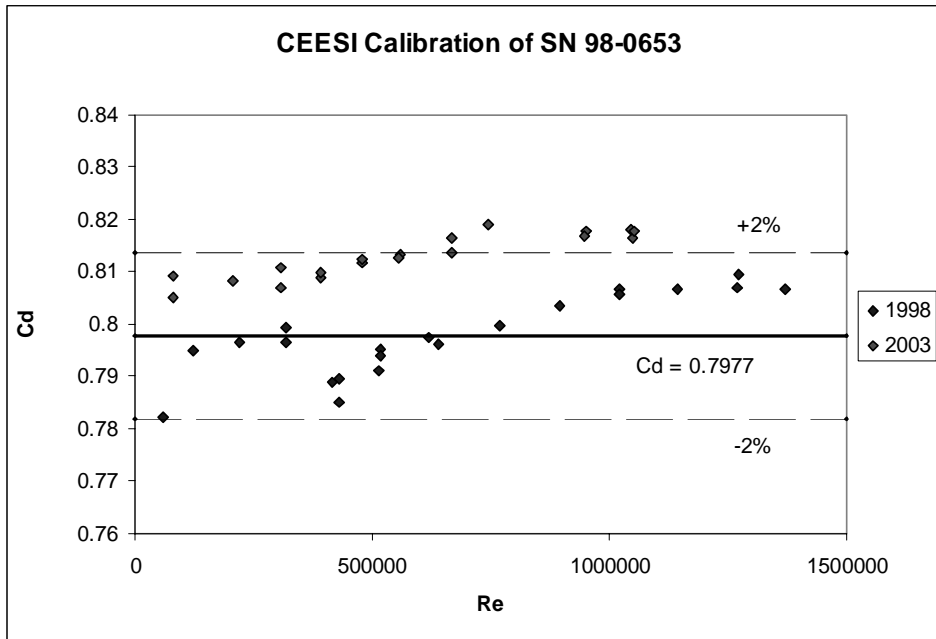

Fig 9: Flow Testing of Meter 98-0653

Meter 98-0655 (Natural Gas).

This meter exhibits very close agreement between the results over the 5 year span even in the uncleaned condition and in fact cleaning the meter made little difference. This meter confirms the fact that certain meters do not require recalibration over this time frame.

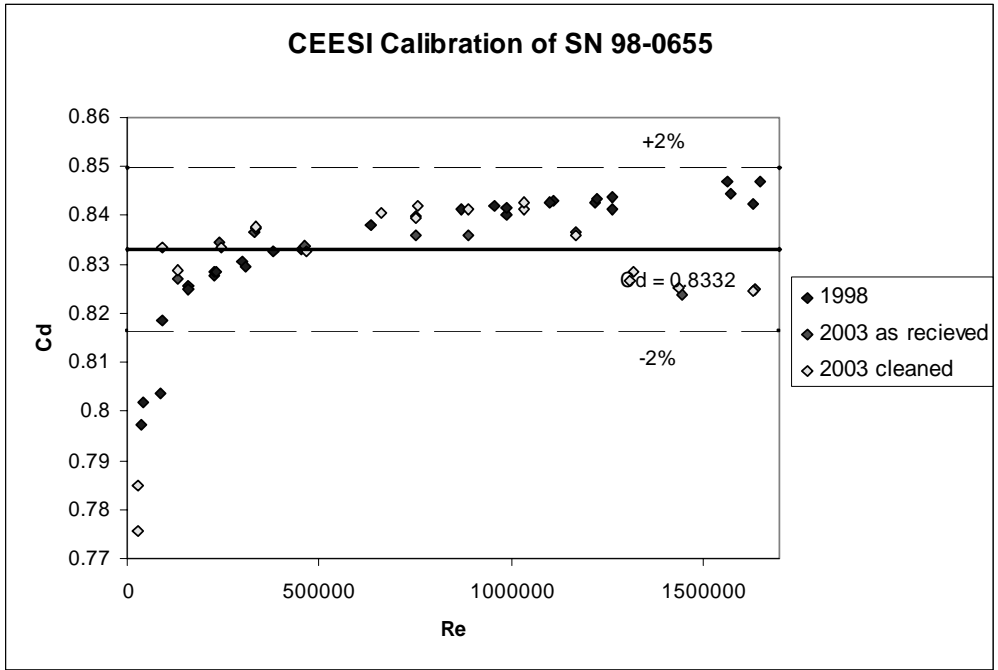

Fig 10: Flow Testing of Meter 98-0655 with as-received and post cleaning g data

Meter 98-0656 (Natural Gas).

Again this meter shows virtually no variation in the results over a five year period and confirms the fact that V-cone meters in Natural Gas application do not require to be re-calibrated in that time frame.

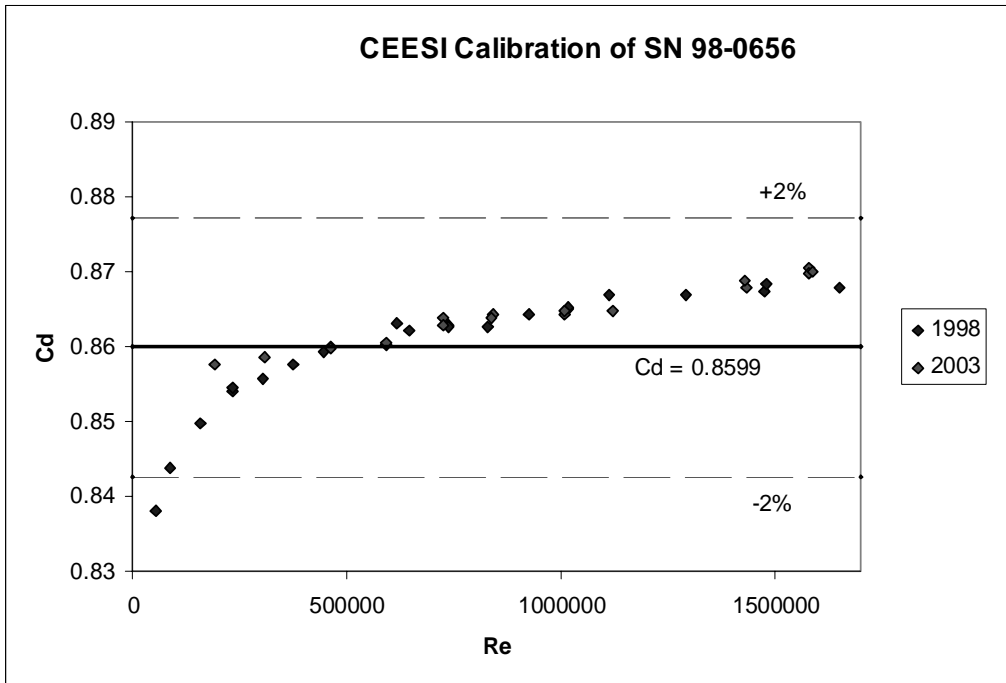

Fig 11: Flow Testing of Meter 98-0656

GENERAL CONCLUSIONS

It can be seen from these results that Citizens Thermal Energy has retested the meters in accordance with the strict interpretations of the EPA requirements. This is an expensive exercise as the meters have to be removed from service and sent to the calibration facility. As well, the cost of the calibration is incurred. This cost can be extended up to twenty QA operating quarters as defined in the regulations through the use of fuel flow to load testing. However, there are challenges presented with the use of this testing.

From the results it can be seen that in each case the calibrations fall within the +/-2% requirement even before cleaning of the fuel flow meters. Following cleaning, the calibration reveals that the meter was in line with the original calibration.

The V-cone fuel flow meter behaves in a very consistent manner even in the Coke Oven Gas application over an extensive period of flow. Through a boroscope inspection of the line while the meter is in-situ, the authors believe that it can be determined whether the meter has any material build up and consequently should be removed, cleaned and recalibrated. Based on the data presented, it would appear that the annual calibration requirement (notwithstanding the use of fuel flow to load testing) could be considerably extended without compromising the integrity of the data generated by the fuel flowmeter.

While the retesting of these particular meters was completed for the purpose of examining and presenting information to the EPA, it is shown from this study that V-Cones in natural gas (and coke oven gas) service will not require extensive and/or expensive retesting/recalibration, as they perform well within the required +/-2% accuracy. In most cases, the V-Cone meters will not require maintenance for a considerably extended period of many years, and that leads to greatly reduced costs and savings for the operating facility.

Addressing the Regulatory Limitations

The fuel flow meter calibration and quality assurance guidelines found at 40 CFR 75, Appendix D, were written for long established technologies which have had standards written for them, albeit these standards continue to be revised even for the basic equations. Newer fuel flow meters based on technologies which have no standards written for them are subject to more stringent requirements. In the case of the V-Cone, because it is a patented technology, the fuel flow meters are subject to administrative burdens which may have no additional value.

In the light of the results of calibrations presented herein, the authors believe that EPA should allow the V-cone fuel flow meter to meet the requirements of 40 CFR 75, Appendix D, in the same manner as other differential pressure meters.

OTHER McCROMETER PRODUCTS INCLUDE:

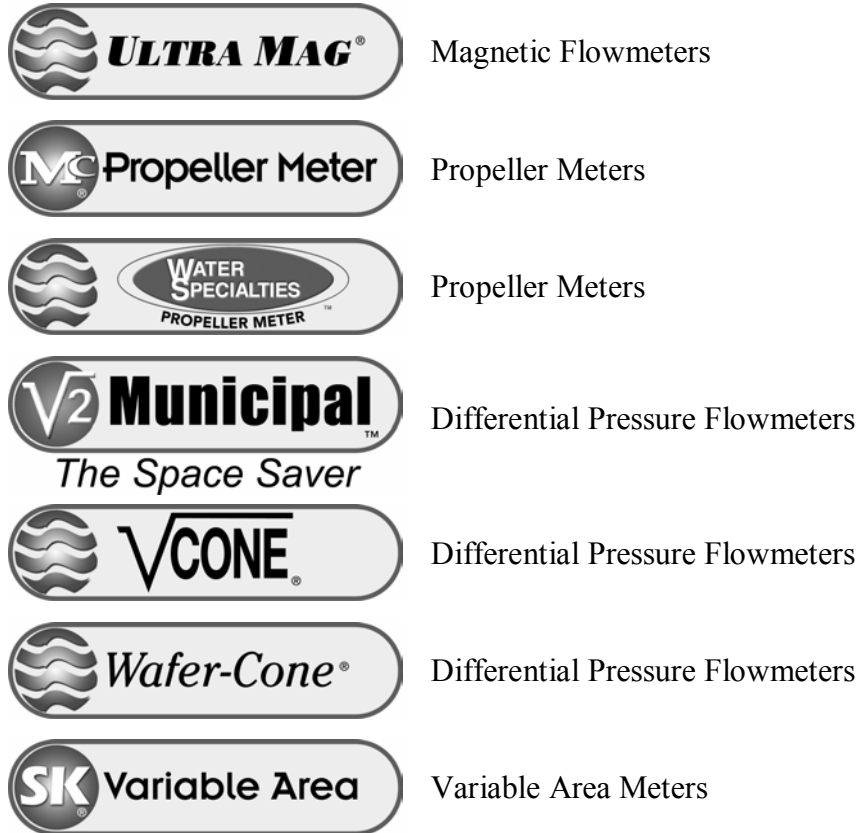

Electronic Instrumentation for Remote Display and Control

FOR MORE INFORMATION CONTACT:

Represented by:

 **McCROMETER**
3255 W. Stetson Avenue, Hemet, CA 92545
Phone: (951) 652-6811 Fax: (951) 652-3078
Web Site: <http://www.mccrometer.com>
Hours: 8 a.m. - 4 p.m. PST, Monday-Friday

Canadian Patent 1325113
Lit# 24509-99 Rev 1.1/07-05

European Patent 0277121

U.S. Patents 4638672, 4812049, 5363699, 4944190 and 5,814,738
Japan patent 1,858,116 Other U.S. and Foreign patents pending
Printed in U.S.A. © 2005 by McCrometer, Inc.