

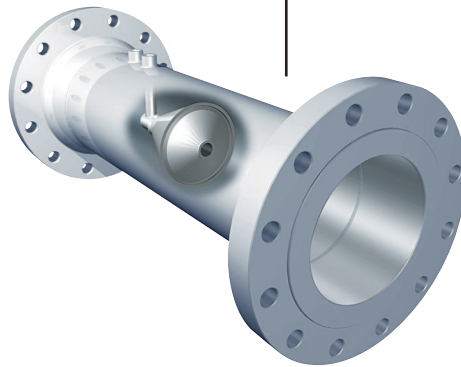

Advanced
Differential
Pressure
Flowmeter
Technology



For The Real World.



V-Cone - A Superior DP Technology

Designed

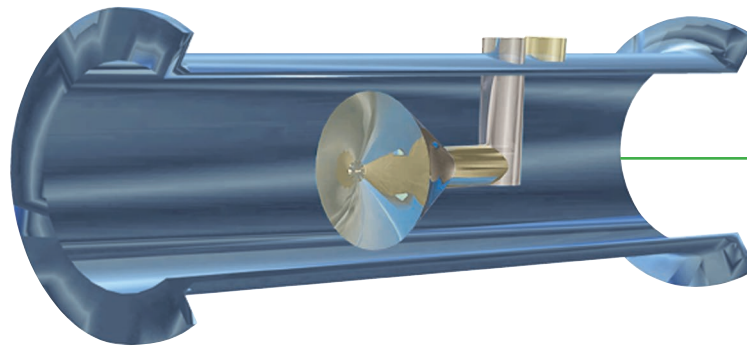

Centrally-located cone directs flow to the outside wall effectively conditioning disrupted flows.

High Performance in "Real World" Applications

McCrometer's V-Cone is an innovative flowmeter that takes differential pressure flow measurement to another level. Designed for mild to harsh operating environments, and for a wide variety of fluids, this advanced flowmeter consistently outperforms traditional DP devices and other flow technologies. The V-Cone offers better accuracy

and repeatability, wider rangeability, installation flexibility and reduced maintenance. Its performance is so outstanding, some users say it deserves a technology name all its own.

Accuracy You Can Count On

The key benefit to the V-Cone's unique design is its ability to provide repeatable accuracy of up to $\pm 0.5\%$ of rate under even the most difficult flow conditions, and over a wide range of Reynolds numbers. Whether measuring swirling

fluids or low pressure flows, the V-Cone delivers the accuracy and reliability other devices only achieve under laboratory conditions.

Acts As Own Flow Conditioner

The V-Cone's enhanced performance is due to the shape and position of the cone in relation to the measurement ports. This allows the V-Cone to act as its own flow conditioner by disrupting

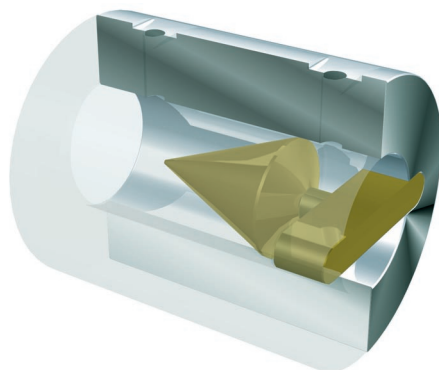
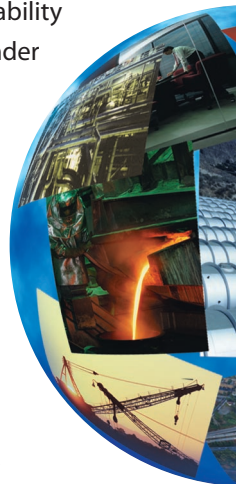

The Wafer-Cone® is fitted between two flanges for more compact installation. It is available in a variety of materials and the cone can be easily replaced to accommodate changing flow conditions.

for Difficult-to-Measure Applications

all centralized flow disturbances. This fully mixed and conditioned flow results in a low amplitude, high frequency signal with little "signal noise."

Readings are always precise and reliable, including low pressure flow situations.

Maximum Installation Flexibility

The V-Cone's ability to condition the flow prior to measurement results in another

significant benefit: installation flexibility. Because the V-Cone can accurately measure disturbed flow, it doesn't require the upstream or downstream straight pipe runs of many other flowmeters. This key feature means the V-Cone can be installed virtually anywhere in a piping system or easily retrofit into an existing piping layout. The result can be significant cost savings. It also means the V-Cone can fit where other flowmeters can't due to limited space or weight requirements.

Low-to-No Operating Costs

The V-Cone assures long-term performance. It has no moving parts to replace and maintain. In addition, the contoured shape of the cone directs the flow without impacting it against an abrupt surface. Instead, a boundary layer forms along the cone, directing fluid away from the beta edge. Because the beta remains unchanged, the calibration of the meter is accurate for a much longer time, possibly indefinitely.

The V-Cone forms very short vortices as the flow passes the cone. These short vortices create a low amplitude, high frequency signal for excellent signal stability.

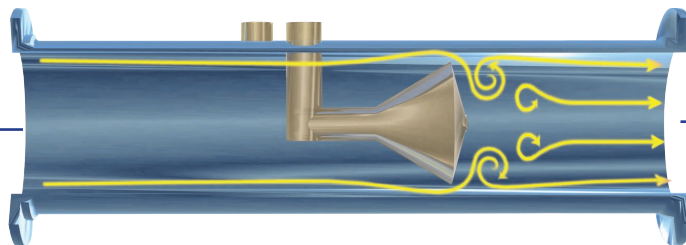

The V-Cone's contour-shaped cone directs the flow without impacting it against an abrupt surface. As a result, the beta edge of the cone is not subject to wear by dirty fluids. Because the beta edge remains unchanged, V-Cones rarely, if ever, require recalibration.

V-Cone Performance Advantages

The contoured shape and location of the suspended cone in the V-Cone Flowmeter reshapes the velocity profile upstream. As the flow approaches the cone, the flow profile "flattens" toward the shape of a well-developed profile - even in extreme flow conditions.



Flexible Design Meets Range of Needs

The V-Cone Flowmeter offers exceptional sizing flexibility. It can be sized for line diameters of 1/2" to over 120". An extensive variety of construction materials are also available.

McCrometer Application Support

At McCrometer, all we make are flowmeters. We have over 50 years

of flow measurement experience in municipal, industrial and agricultural markets.

Our knowledgeable staff can accurately evaluate your flow application and specify the best metering technology for your specific flow condition. For an evaluation of your flow application or to find out about our other flowmeter products, contact your McCrometer representative today.



high accuracy

high repeatability

self conditioning

minimum straight pipe requirements

broad rangeability

low headloss

clean or dirty liquids, wet gases, slurries

low signal noise

virtually no maintenance

Real World Measurement Applications

Ideal For
Tough
Applications



The McCrometer V-Cone Flowmeter technology accurately measures flow over a wide range of Reynolds numbers, under all kinds of conditions and for a variety of fluids. It operates on the same physical principle as other differential pressure-type flowmeters, using the theory of conservation of energy in fluid flow through a pipe. The V-Cone's remarkable performance characteristics, however, are the result of its unique design. It features a centrally-located cone inside the tube. The cone interacts with the fluid flow, reshaping the fluid's flow profile and creating a region of lower pressure immediately downstream of itself. The pressure difference, exhibited between the static line pressure and the low pressure created downstream of the cone, can be measured via two pressure sensing taps. One tap is placed slightly upstream of the cone, the other is located in the downstream face of the cone itself. The pressure difference is then incorporated into a derivation of the Bernoulli equation to determine the fluid flow rate.

The cone's central position in the line optimizes the velocity of the flow at the point of measurement, assuring highly accurate, reliable flow measurement regardless of the flow condition upstream of the meter.

Advanced DP
Technology:
Principles of
Operation

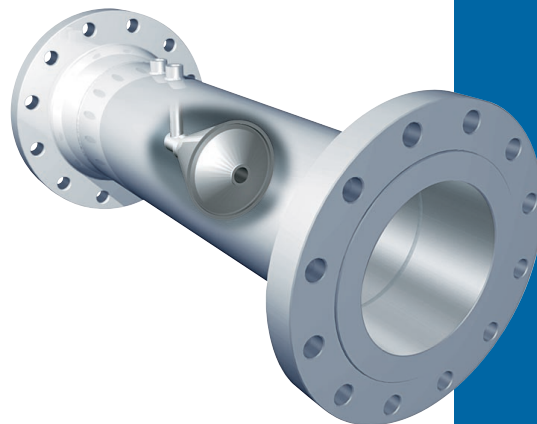

oil & gas production
and delivery

•
petroleum refining

•
municipal water &
wastewater

•
chemical/
pharmaceutical
processing

•
power/co-generation

•
mining

•
pulp & paper

•
industrial
manufacturing

•
food & beverage

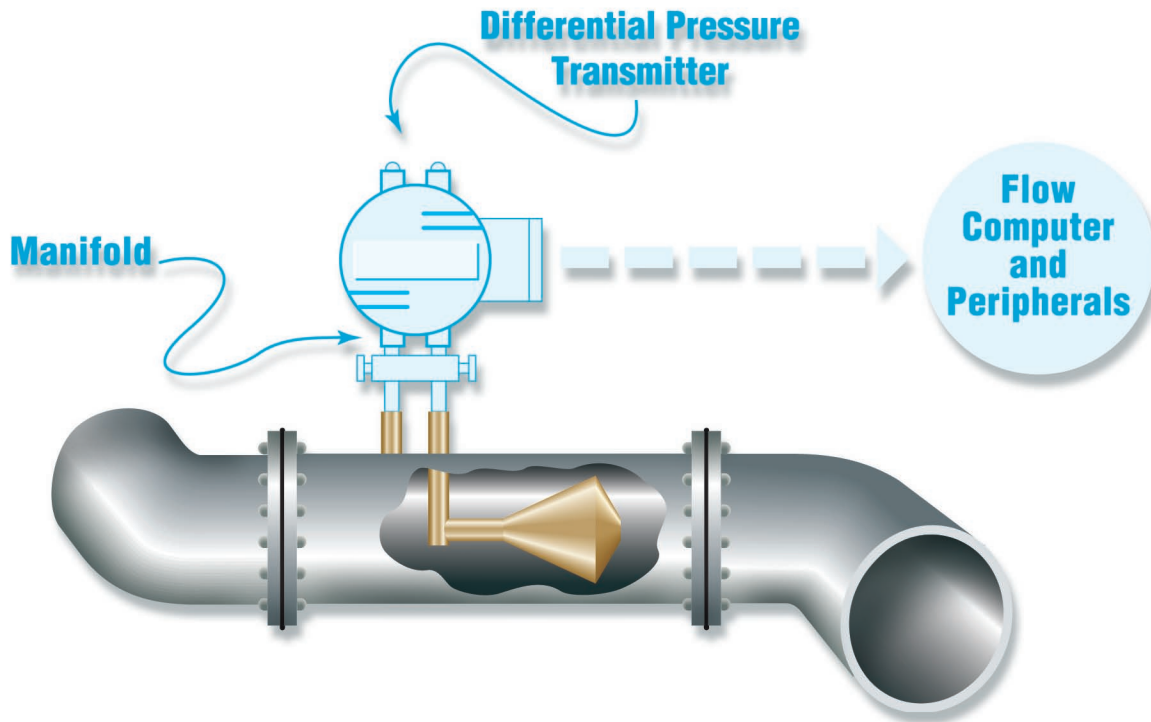

Standard Accuracy: From $\pm 0.5\%$ of actual flow (certain fluids and Reynolds number applications require special calibrations to achieve this value).

Repeatability: $\pm 0.1\%$ or better.

Flow Ranges: 10:1 and greater.

Standard Beta Ratios: 0.45 through 0.80, special betas available.

Head Loss: Varies with beta ration and DP.

Installation Piping Requirements: Typically 0-3 diameters upstream and 0-1 diameters downstream of the cone are required, depending on fittings or valves in the adjacent pipeline.

Materials of Construction Include: Duplex 2205, 304, or 316 stainless steel, Hastelloy C-276, 254, SMO, carbon steels. Special materials on request.

Line Sizes: 0.5" to 120" or larger.

End Fittings: Flanged, threaded, hub or weld-end standard. Others on request.

Configurations: Precision flow tube and wafer-type.

- Calibrated for customer application.
- ASME B31.3 construction available.

Approvals for the V-Cone:

- Canadian custody transfer approved.
- Meters in compliance with PED97/23/EC are available upon request.
- ISO 9001:2000 certified quality management system.



www.mccrometer.com

3255 West Stetson Avenue, Hemet, California 92545 USA
Phone 800-220-2279 | 951-652-6811 | Fax 951-652-3078

© 2009-2010 by McCrometer, Inc. / Printed in USA Lit Number 24509-49 Rev. 2.0 / 04-10
U.S. Patents 4812049, 5363699 and 5,814,738; Including Patents Applicable Outside The U.S.; Other U.S. and Foreign patents pending