

MODEL VJ

JIS Slip-On - 10k or 20k

DESCRIPTION AND GENERAL PERFORMANCE SPECIFICATIONS

The V-Cone® flowmeter is a patented, differential pressure type flow measurement device. A cone is positioned in the center of the pipe to increase the velocity of the flowing fluid and create a differential pressure. This pressure difference can be measured and used to accurately interpret flowrate. Two taps are provided on every V-Cone to allow sensing of the high and low pressures. A typical V-Cone application can follow these general performance specifications:

- Accuracy: up to ±0.5% of rate
- Repeatability: ±0.1%
- Turndown: 10:1
- Standard Betas: 0.45 through 0.85
- Headloss: Percentage of differential pressure produced varies with beta ratio.
- Installation: Typically 0-3 diameters upstream and 0-1 diameters downstream.

* Each V-Cone is sized for the intended application. Specific performance ratings must be obtained through the sizing process.



The V-Cone is manufactured under a quality management system that is certified to ISO 9001:2000.

MODEL VJ DIMENSIONS

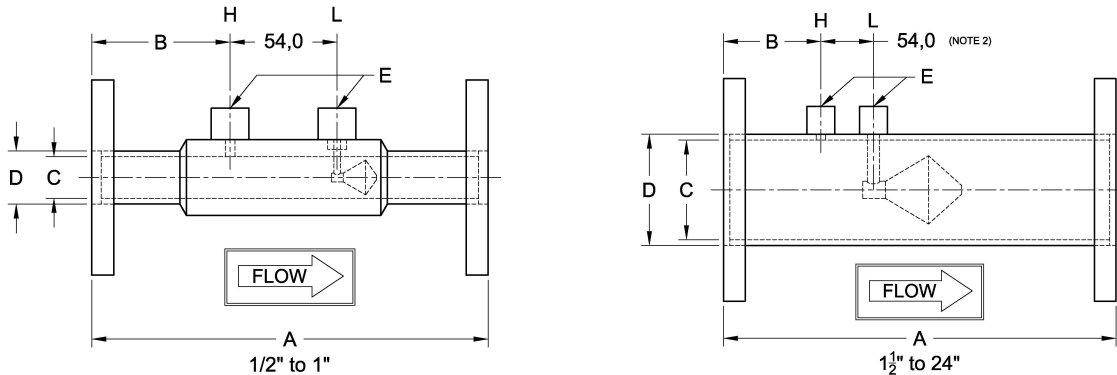

DIMENSION TABLE

| Size | A (Note 1) | B | C-Stainless (Note 2) | C-Carbon (Note 2) | D | E (Note 2) |
|-------|---------------|-----|-------------------------|----------------------|------|---------------|
| inch | mm | mm | mm | mm | mm | RC |
| 1/2 | 203 | 75 | 15,8 | - | 21,3 | 1/4 |
| 3/4 | 203 | 75 | 20,9 | - | 26,7 | 1/4 |
| 1 | 203 | 75 | 26,64 | - | 33,4 | 1/4 |
| 1 1/2 | 254 | 76 | 41,78 | - | 48,3 | 1/4 |
| 2 | 305 | 89 | 53,44 | - | 60,3 | 1/2 |
| 2 1/2 | 305 | 89 | 63,60 | - | 73,0 | 1/2 |
| 3 | 356 | 89 | 78,84 | - | 88,9 | 1/2 |
| 4 | 406 | 102 | 103,8 | - | 114 | 1/2 |
| 6 | 559 | 108 | 154,1 | 154,1 | 168 | 1/2 |
| 8 | 660 | 127 | 202,7 | 202,7 | 219 | 1/2 |
| 10 | 711 | 127 | 254,5 | 254,5 | 273 | 1/2 |
| 12 | 762 | 133 | 304,8 | 303,3 | 323 | 1/2 |
| 14 | 762 | 152 | 336,6 | 333,5 | 355 | 1/2 |
| 16 | 762 | 152 | 387,4 | 381,0 | 406 | 1/2 |
| 18 | 813 | 152 | 438,2 | 438,2 | 457 | 1/2 |
| 20 | 914 | 152 | 489,0 | 489,0 | 508 | 1/2 |
| 24 | 1219 | 254 | 590,6 | 590,6 | 609 | 1/2 |

1. Overall length (A) tolerance varies with line size: 1/2" to 1", ±1/16" (±2mm); 1 1/2" to 10", ±1/8" (±4mm); 12" to 24", ±3/16" (±6mm)
2. Typical values shown.
3. Wall pressure ports are required for vertical up flow applications.



CONFIGURATION SHEET

MODEL NUMBER CONFIGURATION VJ

| Type | Size | | Materials‡ | | Pipe Schedule | | End Connections | | Fittings | |
|-----------|------|-----|------------|--------------------------------------|---------------|-----|--------------------------|-------------------------------|---------------------------|--------|
| VJ | | | | | | | | | | |
| | 0A | ½" | Q | S304 | A | 10 | 26 | JIS 10k | N | NPT |
| | 0B | ¾" | L | S304L | B | 20 | 27 | JIS 20k | S | Socket |
| | 01 | 1" | A | S316L | D | Std | | | J | JIS RC |
| | 0C | 1½" | N | S304 Tube, Cone, Support & Couplings | E | 40 | | | Several types of fittings | |
| | 02 | 2" | | CS Steel Flanges | F | 80 | | | | |
| | 0D | 2½" | | Flanges painted | J | 100 | | | | |
| | 03 | 3" | S | CS Tube & Flanges | K | 120 | | | | |
| | 04 | 4" | | S304 Cone, Support, & Couplings | L | 140 | | | | |
| | 06 | 6" | | Epoxy Coated Blue (excluding cone) | G | 160 | | | | |
| | 08 | 8" | U | CS Tube & Flanges | H | XXS | | ‡Other materials can include: | | |
| | 10 | 10" | | S304 Cone, Support, & Couplings | M | 10S | | HASTELLOY C-276 | S321H | |
| | 12 | 12" | | Coating / Painting Per Customer Req. | P | XS | | DUPLEX 2205 | INCONEL 625 | |
| | 14 | 14" | | | | | | CHROMEMOLY P22/P11 | | |
| | 16 | 16" | | | | | | MONEL K400/K500 | | |
| | 18 | 18" | | | | | | CARBON STEELS | | |
| | 20 | 20" | | | | | A350, A333, API5L, A106B | | | |
| | 24 | 24" | | | | | | | | |

Example: VJ01QE26J V-Cone 1 inch line size, S304, schedule 40 pipe, JIS 10k, RC ¼" fittings

STANDARD PIPE SCHEDULES

| Stainless Steel | | Carbon Steel | |
|-----------------|------|--------------|------|
| Size | Std. | Size | Std. |
| ½" to 10" | E | 6" to 16" | E |
| 12" and up | D | 18" and up | D |

Meters 6" and smaller utilize seamless pipe.
Meters 8" and larger utilize welded pipe.

ABBREVIATIONS

| | | | |
|------|--|----|---------|
| ASME | American Society of Mechanical Engineers | | |
| JIS | Japanese Industrial Standard | | |
| NPT | National pipe taper | | |
| SS | Stainless steel | | |
| CS | Carbon steel | SO | Slip On |

Technical questions can be answered through a local representative or through our application engineers.

MANUFACTURING STANDARDS

McCrometer's welders and welding procedures are qualified in accordance with ASME Section IX. All meters are visually inspected for weld defects. Specific customer requirements can be complied with upon request.

The welding can be in accordance with:

- ASME Section VIII
- ASME B31.1
- ASME B31.3

Non-destructive testing can include:

- Hydrostatic Pressure Testing
- Penetrant Examination
- Radiographic Examination
- Positive Material Inspection
- Magnetic Particle Examination

REPRESENTED BY: