

SIGNAL NOISE RATIO COMPARISON WITH V-CONE AND ORIFICE PLATE

Stephen A. Ifft
Flow Measurement Technology Manager
McCrometer Inc., USA

SUMMARY

This paper discusses and compares the relative signal noise between the V-Cone differential pressure flowmeter and a typical orifice plate differential pressure flowmeter. For this paper, signal noise shall be defined as the fluctuations in the differential pressure signal at a constant flowrate. Users of V-Cones have often commented on the significant drop in signal noise experienced when using a V-Cone instead of a traditional orifice plate. Many times the most noticeable differences were experienced in disturbed flow conditions. This drop in noise allowed the users better signal readings with less damping of the differential pressure transmitter.

To quantify this information, McCrometer conducted a series of tests comparing the signals from a V-Cone and a typical orifice plate. The tests were conducted at McCrometer using air as the test fluid. The meters were placed downstream of two disturbances in the same line: a 90° elbow and a partially closed gate valve. This created a disturbed flow condition.

Test results thus far indicate the V-Cone has significantly less signal noise when compared to a typical orifice plate.

INTRODUCTION

Signal noise can have a notable effect on the operation of a process system. Often a flowmeter signal is used as a process control and must respond instantly to changes in flowrate. Differential pressure (DP) flowmeters have no moving parts and have an instantaneous response to any changes in flowrate. Unfortunately, traditional DP meters, such as orifice plates and venturis, also respond instantly to *disturbances* in the flow line. These disturbances can be caused by common pipeline elements such as elbows and valves. The DP signal from the meters will show the disturbance fluctuations on top of the flowrate signal. Such fluctuations necessitate the need to time average (dampen) the signal. The orifice plate can also create additional noise due to the recirculating area downstream of the plate.

Dampening of the DP signal usually occurs within the DP transmitter and effectively lengthens the response time of the flowmeter system. This is not acceptable in many critical applications.

An example of this is an “anti-surge” meter used prior to a natural gas compressor, see Figure 1. These meters are used to measure the flow of natural gas into the compressor. If an unusually high flow is detected, the control system must shut down the compressor within seconds to avoid overspinning the gas turbine. If the flowmeter system requires dampening, the response time would leave little room for error.

Signal noise can also cause trouble within a dynamic control system. A fluctuating DP signal can cause a control system to “wander”, or continually adjust. A smoother signal could allow fast response without loss of stability.

TESTING

Test procedure

The following equipment was used in this first series of tests:

Equipment	Manufacturer	Information
¾” V-Cones, betas 0.45, 0.60, 0.75	McCrometer	model VP0BQCOON
¾” orifice plates, betas 0.45, 0.60, 0.75	Flomax	
DP transmitter	Rosemount	model 3051C
Absolute pressure transmitter	Mensor	model 4020
100 Ω platinum RTD temperature probe	Omega	model PR-11-3-100-3/16-2-E
Data acquisition software and hardware	LabView	version 4.0

For each test point, the same instrumentation was used to measure the DP signal. Thus any system fluctuations would be measured equally by both meters. The test piping is shown in Figure 2.

Test points were collected over sixty seconds. This time allowed for several periods of the signal fluctuations to be measured. One hundred data points were taken each second, for a total of 6000 points for each flowrate tested. Line pressure was 50 psia for all tests. Line temperature was approximately 70°F for all tests.

Test results

Since the V-Cone and the orifice plate will create different signal levels at the same flow, several methods exist to compare data between the two meters. Two approaches are given here.

- Method 1: compare the relative signal noise at the same Reynolds number and linear velocity.
- Method 2: compare the relative signal noise at the same differential pressure level.

Figure 3, 4, and 5 use method 1 to compare the results with beta ratios 0.45, 0.60, and 0.75, respectively, at matching Reynolds numbers and linear velocity. This allows comparison between the meters at similar line conditions. Since the meters respond differently, the differential pressure readings from the V-Cone will be different than from the orifice plate.

Figures 6, 7, and 8 use method 2 to compare the results with beta ratios 0.45, 0.60, and 0.75, respectively, at matching differential pressure levels. This allows comparison between the meters at the same signal level but at different line conditions.

The following table summarizes the results:

Meter	Beta ratio	Differential Press (“wc)	Reynolds # Re	Velocity (ft/s)	Noise ratio σ/DP	Noise ratio to V-Cone
V-Cone	0.45	25	46,000	31	0.0013	
Orifice plate	0.45	50	46,000	31	0.0036	2.8
Orifice plate	0.45	25	32,000	22	0.0038	2.9
V-Cone	0.60	25	118,000	45	0.0014	
Orifice plate	0.60	50	118,000	45	0.0029	2.1
Orifice plate	0.60	25	84,000	32	0.0026	1.9
V-Cone	0.75	25	100,000	130	0.0013	
Orifice plate	0.75	50	100,000	130	0.0038	2.9
Orifice plate	0.75	25	80,000	100	0.0045	3.5

The “noise ratio” of σ/DP is the ratio of the standard deviation to the average level of the differential pressure signal at each test point. This ratio allows a direct comparison between the meters at different conditions.

The “noise ratio to the V-Cone” shows the ratio of noise ratios. This is the relative amount of noise from the orifice plate to the V-Cone. A value of 2.8 means the orifice plate signal showed 2.8 times the noise that the V-Cone showed.

CONCLUSION

Results from comparing V-Cones and orifice plates indicate that signal noise is less in a V-Cone. At both matching flowrates and matching DP levels, the V-Cone signal noise was significantly lower. This confirms the observations of many V-Cone users.

The stability of the V-Cone signal can be attributed to the geometry of the meter. The downstream pressure port is located in the center of pipe, facing downstream. This central tap measures the “integrated” flow coming around the cone. The flow is integrated as it passes around all 360° of the cone. Thus disturbances are mixed just downstream of the cone, where the low pressure tap is located. The orifice plate uses wall taps that are subject to the recirculating eddies downstream of the plate. These eddies do not integrate disturbances in the flow, and may magnify them.

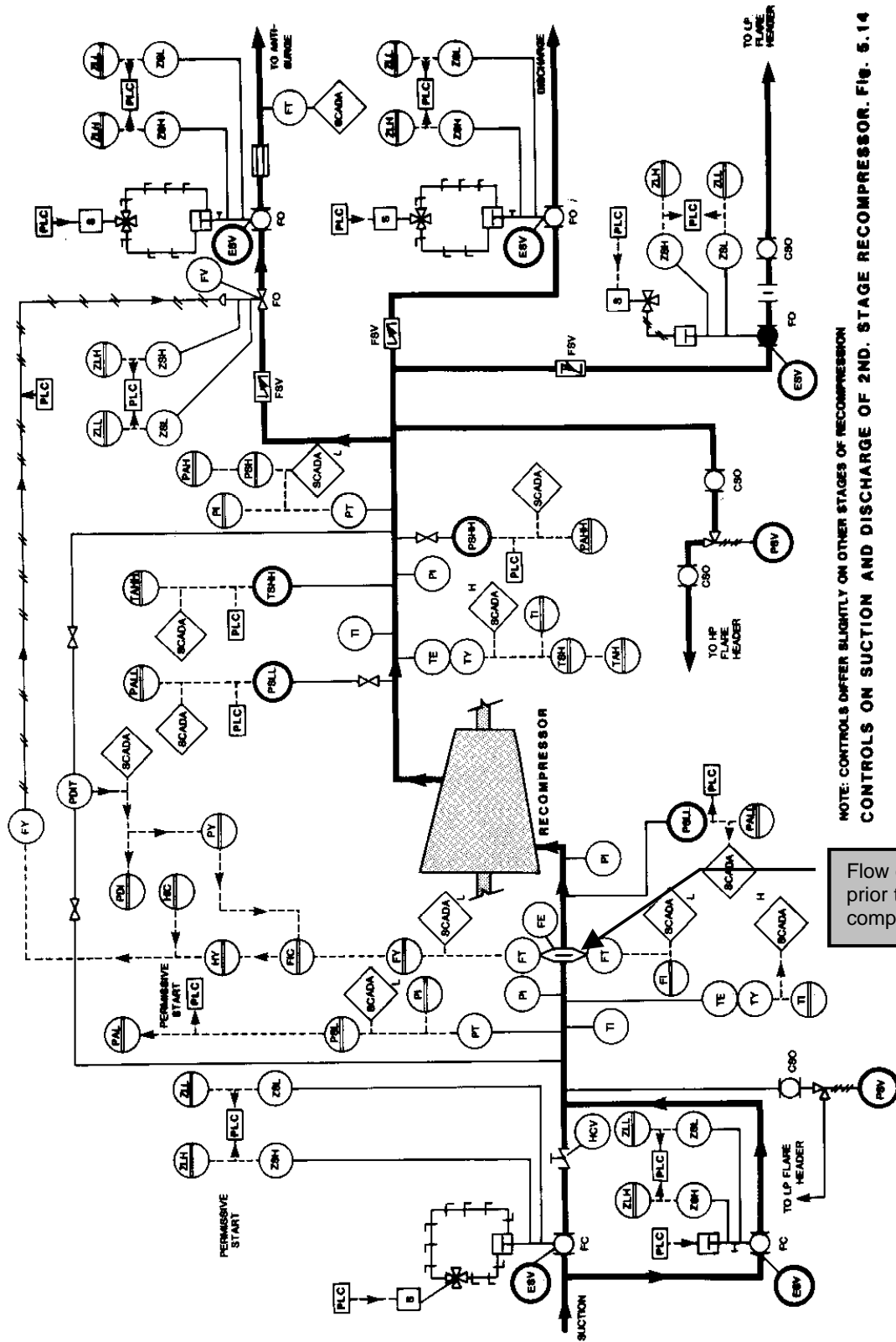

NOTE: CONTROLS DIFFER SLIGHTLY ON OTHER STAGES OF RECOMPRESSION
 CONTROLS ON SUCTION AND DISCHARGE OF 2ND. STAGE RECOMPRESSOR. FIG. 5.14

Flow element prior to compressor

Figure 1.

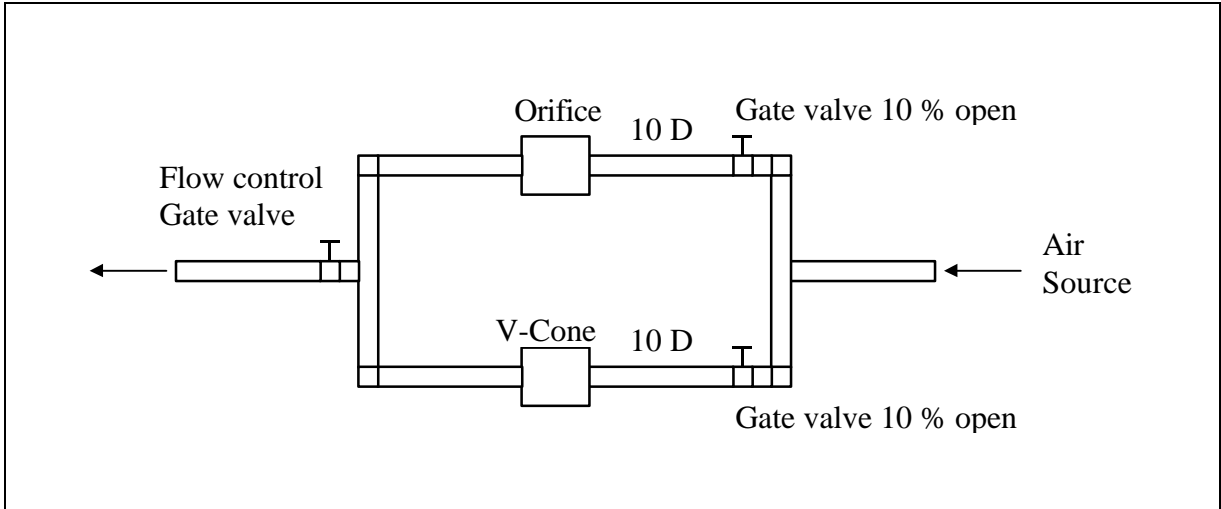

Figure 2.

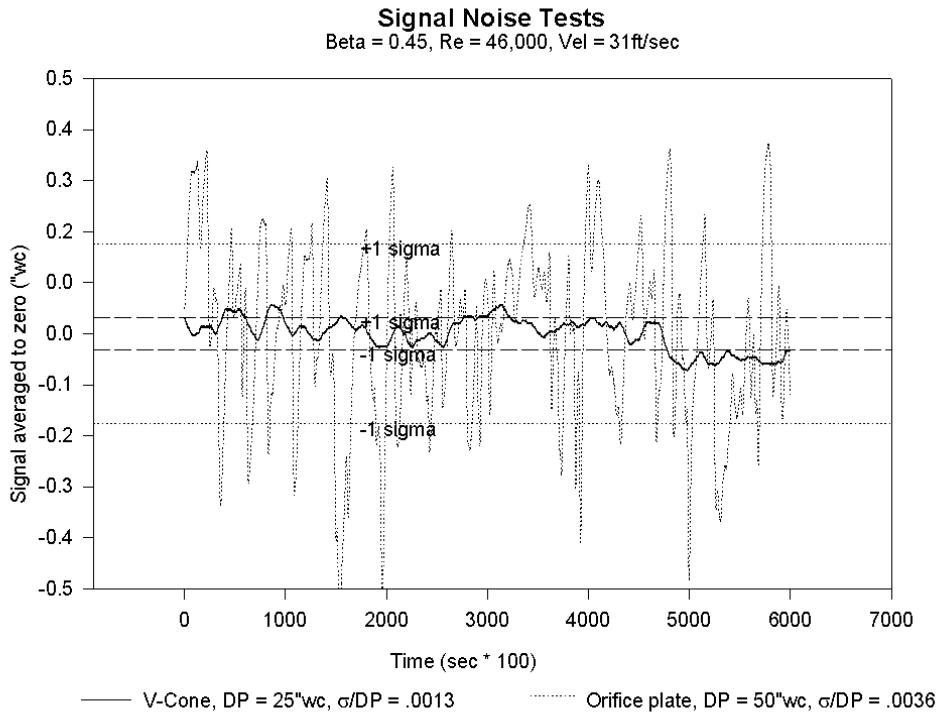

Figure 3.

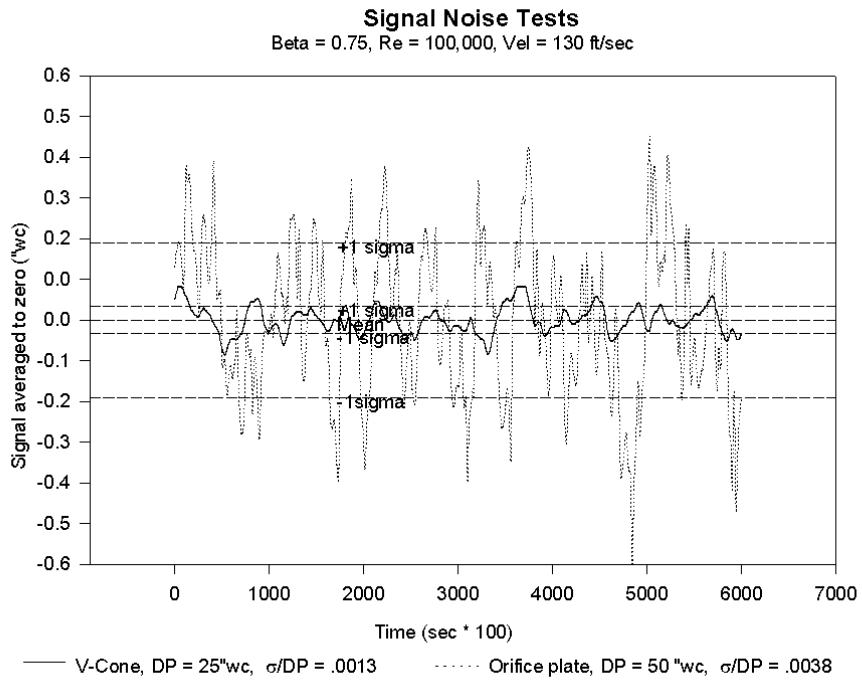

Figure 4.

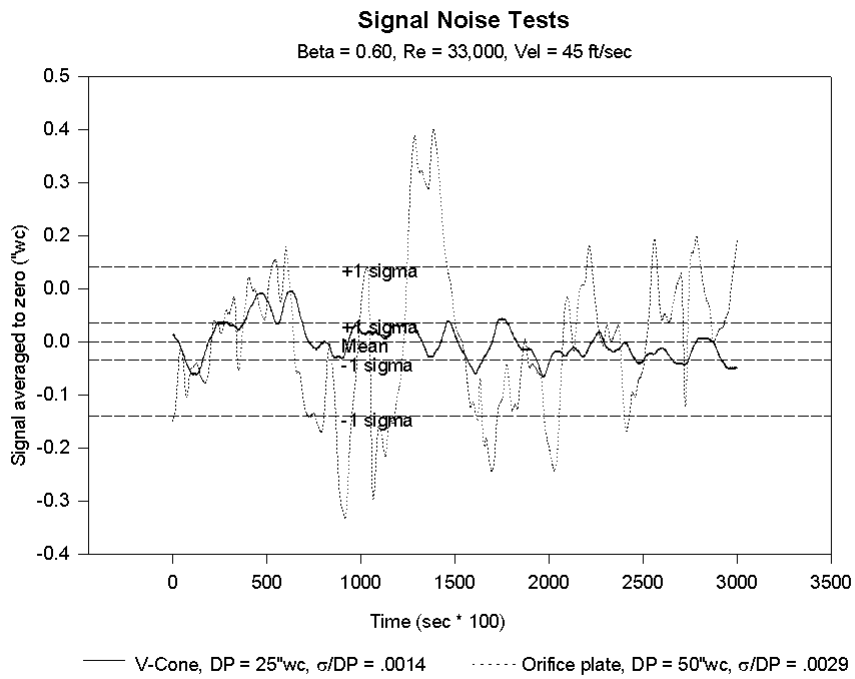

Figure 5.

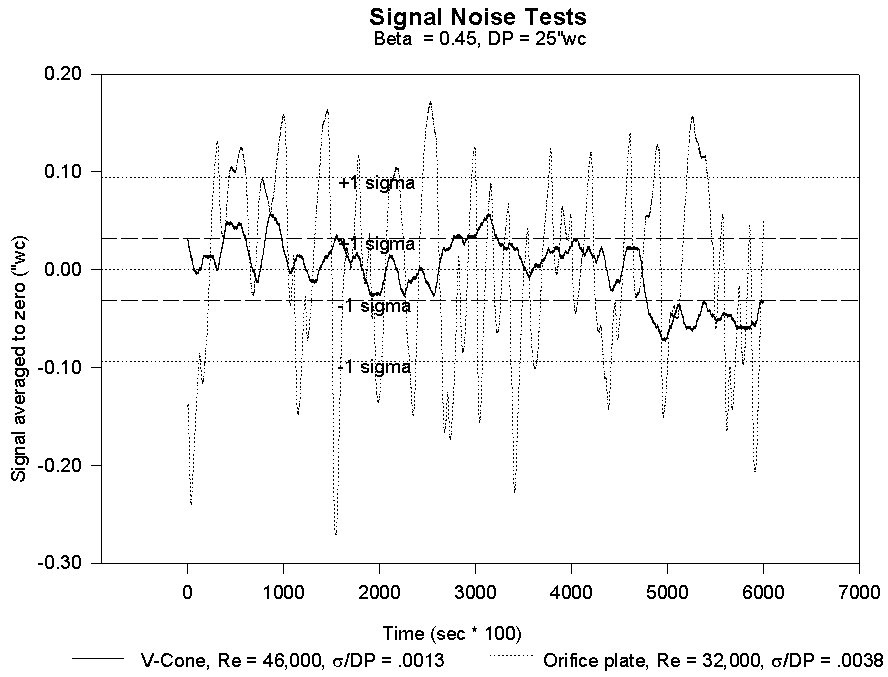

Figure 6.

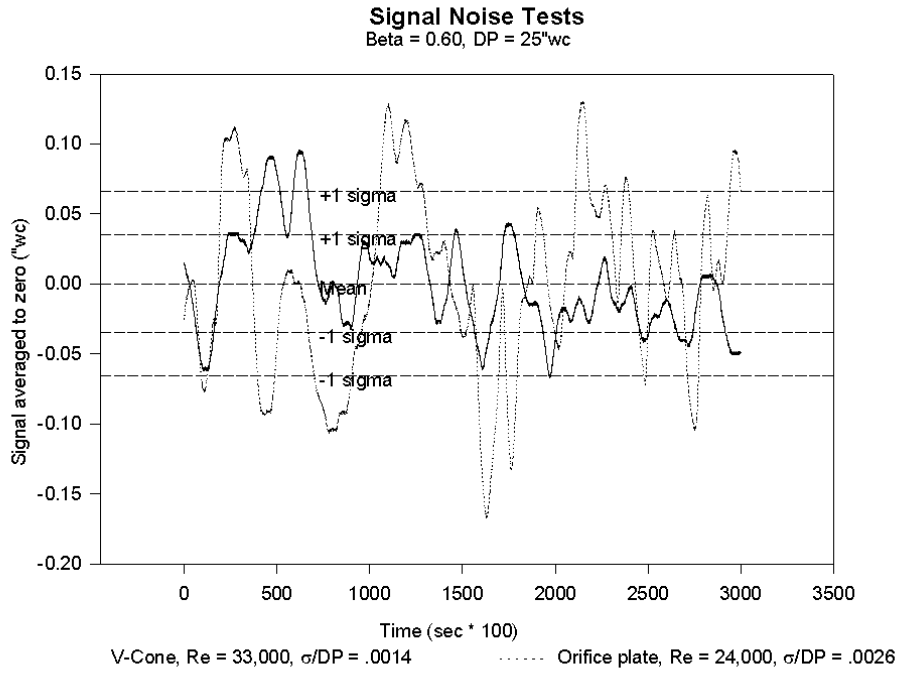

Figure 7.

Signal Noise Tests
Beta = 0.75, DP = 25"wc

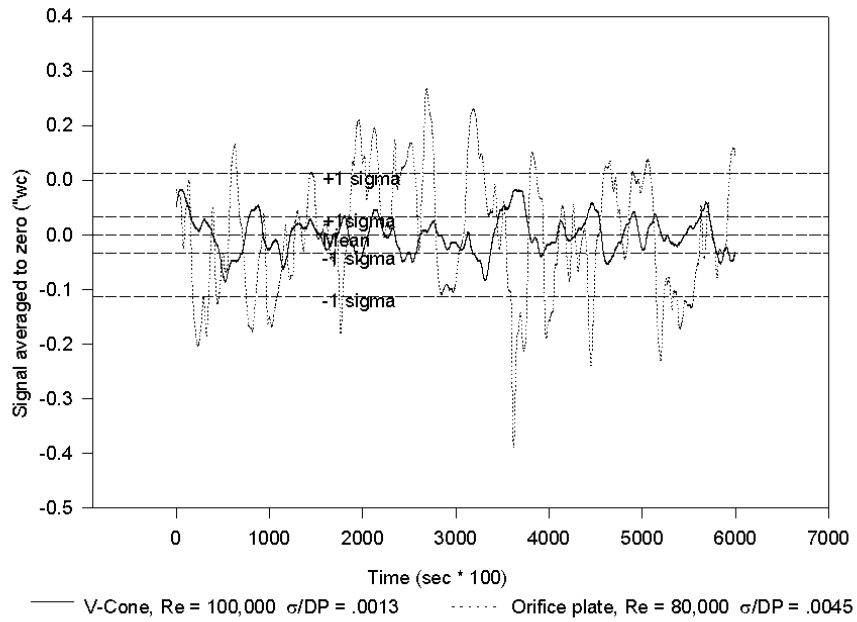

Figure 8.